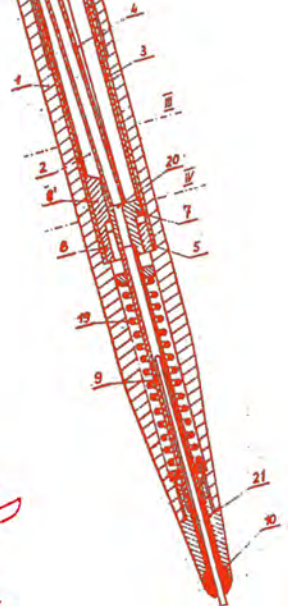
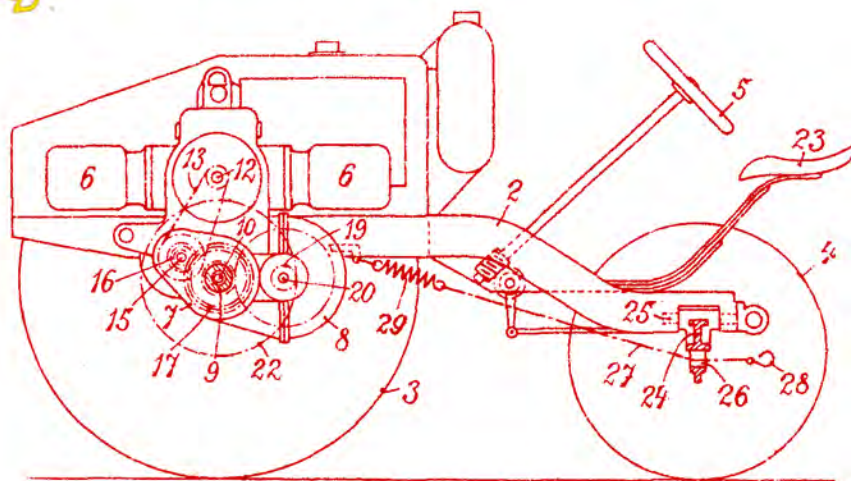

Fig. 1.



Facts & Figures 2023



Hungarian Intellectual
Property Office

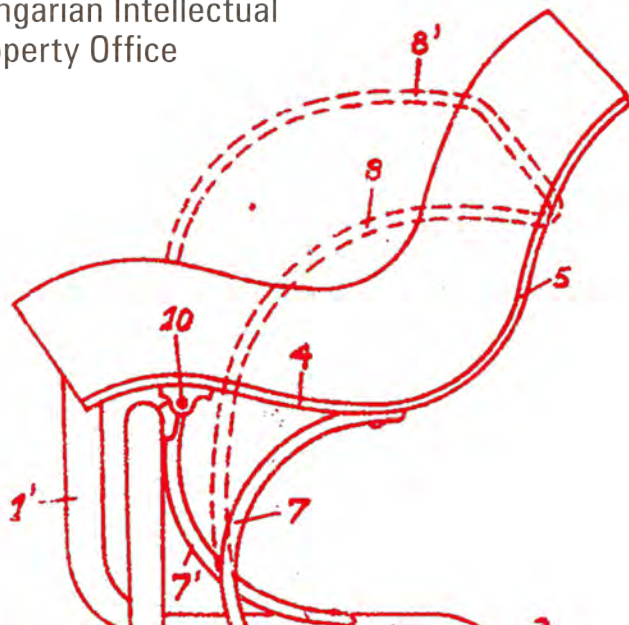
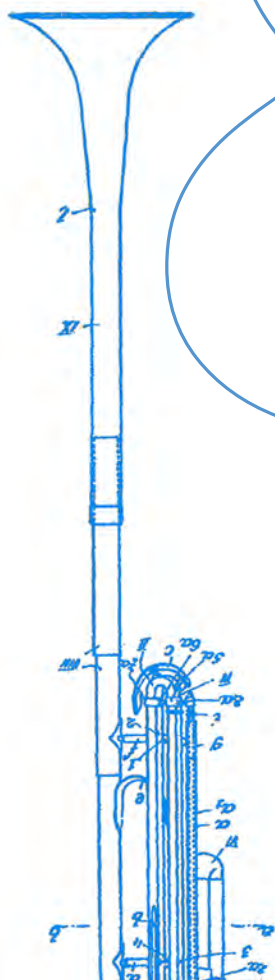

Contents

4

Foreword by
the president

8

The protection
of intellectual
values

10

Customer-
focused
authority

40

Preparation
of laws

42

Copyright
authority

46

International IP
diplomacy

50

Focus on
attitude
shaping

62

Efficient
management

66

Bodies

2023 anniversaries

250 years ago, **Mihály Pollack**, architect and one of the great masters of Hungarian classicist architecture, was born on 30 August 1773

205 years ago, **Ignác Semmelweis**, physician and founder of the aetiology of puerperal fever, was born on 1 July 1818

200 years ago, **Sándor Petőfi**, poet and revolutionary was born on 1 January 1823

200 years ago, **Imre Madách**, Hungarian poet and playwright, was born on 20 January 1823

175 years ago, **Loránd Eötvös**, physicist, inventor, politician, university professor, president of the Hungarian Academy of Sciences, best known for his invention of the torsion pendulum that bears his name, was born on 27 July 1848

125 years ago, **Leó Szilárd**, a nuclear physicist and one of the discoverers of the applicability of the nuclear chain reaction, was born on 11 February 1898

1125 years ago, **Pierre and Marie Curie** discovered radium on 21 December 1898

120 years ago, **János Neumann**, mathematician and the theoretical founder of today's computers, was born on 28 December 1903

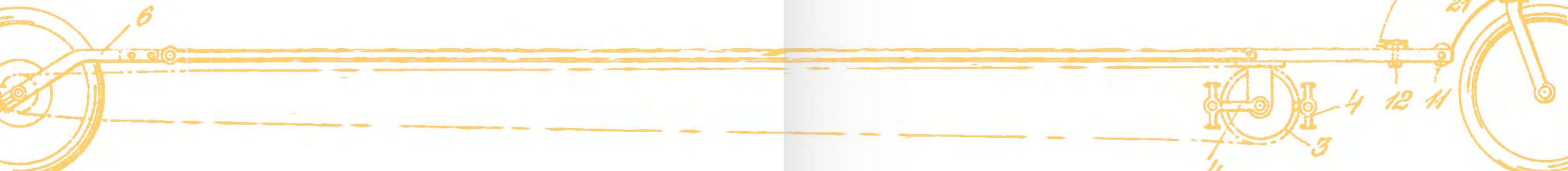

Foreword by the President

Dear Readers,

Almost a year at the helm of the Hungarian Intellectual Property Office (HIPO or Office), I am proud to present to you our publication entitled Facts and Figures 2023, which outlines the main achievements and characteristics of the Office's activities.

This yearbook takes stock of the previous year's activities of the Office as a national industrial property and copyright authority, reports on successful preparatory work for legislation and official work, achievements in the field of services and also looks ahead to the work to be done in the near future.

As a key player in the innovation ecosystem, the HIPO performed its activities in 2023 at a traditionally high level amidst domestic and international challenges and changes.

Among the numerous national anniversaries celebrated in 2023, the 120th anniversary of the birth of János Neumann, the mathematician who laid the theoretical foundations for today's computers, stands out. Let us quote here the timeless saying of the scientist: "If people do not believe that mathematics is simple, it is only because they do not realize how complicated life is."

The innovation strategy, named after János Neumann, was adopted by the National Assembly in 2023 and focuses on strengthening the knowledge-based economy as well as linking universities and research institutions with the economy. The programme set out a number of concrete measures focusing on the protection of intellectual property.

The proposals, which were also embodied in government measures, also affected the scope of the HIPO's activities, inasmuch as from 1 September 2023, the Hungarian Design Council and the certification of R&D activities were transferred from the HIPO to the National Research, Development and Innovation Office and the National Innovation Agency.

In 2023, we managed to adapt the organisational structure to the Office's renewed portfolio as a public authority. We succeeded to reduce the high turnover rate at the beginning of the year and the appointment of new managers in the renewed administrative structure made it possible to start building quality professionalism in the areas of public authority. In addition, we prepared the

Office's strategy for the next 4 years and started preparations for the IP protection-related tasks of the Hungarian Presidency of the Council of the EU in the second half of 2024.

Measures to enhance IPR activity included reducing the filing and maintenance fees by 75% for some targeted groups of applicants (SMEs, universities, research institutes), from which decision-makers expect an increase in the number of applications. However, it is unfortunate that for SMEs and research institutes, the treatment of fee reductions as de minimis aid creates excessive administrative burdens for both customers and the Office, which reduces their uptake. This was already evident in the first quarter 2024 filing data. At the same time, one of the biggest successes of 2023 was our active participation in the development and adoption of the European Patent Organisation's fee reduction scheme, which covers the beneficiaries of the Neumann János Programme and allows them to benefit from a 30% fee reduction on the office fees for the European patent grant procedure from 1 April 2024.

A positive trend is the continuous development of electronic administration in the Office, with the share of e-filings increasing steadily. In line with this trend, from September 2023, the Office's customers will be able to effect their authority fee payments via the virtual bank card terminal (VPOS). To further promote digitalization, from 1 January 2024, e-filings will benefit from a 15% fee reduction.

It is a reason for optimism that, compared to the previous year, the industrial property activity of domestic applicants gained momentum for several protection titles (e.g. trademarks, designs). In the patent field, although there has not yet been a trend reversal in domestic patent filings, we managed to give a small positive boost to the patent activity of Hungarian applicants abroad.

A positive development is the reduction in gross and net administrative pendency time in national patent and trademark procedures, where we feel that we reached the minimum level of time required to meet legal and quality criteria.

The HIPO significantly accelerated the procedure by amending the design protection regulation. As a result of this amendment, the Office will no longer carry out ex officio examination of the requirements of novelty and individual character, nor will it issue a search report, but from 1 January 2024 a protectability opinion will be introduced for customers.

In the field of copyright law the development of generative artificial intelligence brought about a tremendous change, so in addition to its official duties and task of offering legislative advice, the HIPO put great emphasis on scientific and awareness-raising activities on this issue. Besides presentations on this topic at numerous events, the colleagues of the HIPO have also been involved in a number of publication workshops. During the period of our EU Presidency, the evaluation at an expert level of the impact of these processes on intellectual property will remain a topic of priority.

One of the priorities of the past year was to further strengthen the relationship with the universities and SMEs, to increase their activity and to win them as customers. It is encouraging to see that in 2023 also Hungarian universities were among the institutions filing the largest number of national patent applications. New areas of cooperation between universities and the Office have been added, such as IP diagnostics, professional support for university knowledge transfer centres and the renewal and expansion of distance learning.

Distance learning in the field of intellectual property is becoming increasingly popular at universities. While in 2021 only 758 students and in 2022 1 854 students took the exam of the Office's distance learning courses, in 2023, 2 277 higher education students, three times the number in 2021, participated in this form of training.

Two important messages were addressed to SMEs as a priority target group: the free, renewed IP Scan (Intellectual Property Diagnostics) service and the resources for obtaining IP protection (EUIPO SME Fund and NRDH IPARJOG call) proved to be effective messages, resulting in increased participation rates. For example, in 2023, Hungary applied for nearly three times as many SME funds as in 2022, moving up 5 places in the European ranking of countries, placing us in the middle third. We also significantly increased our IP scan numbers, prepared reports to nearly twice as many businesses last year as the year before and conducted a comprehensive IP diagnostic study for a university.

The Office is again actively participating in the work of international intellectual property organisations (WIPO, EPO, EUIPO) and is strengthening its relations with its counterparts in the Central and Eastern European region. The Visegrad Patent Institute launched two new services which allow customers to obtain a response on the novelty and patentability of their invention in just 4 weeks, before filing a patent application.

I am confident that the positive trends will continue in 2024 and the willingness to file, the increase in SME's awareness, the more efficient use of university intellectual property, the even more active international cooperation and, last but not least, the results of our professional work during the rotating EU Presidency will be visible in next year's report as well.



Szabolcs Farkas
President

1 | Protection of intellectual values

The Hungarian Intellectual Property Office (hereinafter “the HIPO” or “the Office”) is the central government office responsible for the protection of the intangible assets of the economy, science and culture. Its activities cover industrial property protection and copyright, and until 1 September 2023 it covered the qualification of research and development activities. The supervision over the Office under government control was exercised by the Minister for Culture and Innovation.

According to the relevant decision of the Prime Minister, a new President, **Szabolcs Farkas**, took over the management of the HIPO as of 1 May 2023. In the exercise of his institutional management and control powers, the President of the HIPO continues to be assisted by **Péter Lábodý**, Vice-President for Legal, International and Innovation Affairs, **Dóra Gyetvainé Virág**, Vice-President for Industrial Property Administration, **Zoltán Horváth**, Director-General, responsible for managing the tasks of the Vice-President for Economic Affairs, and **Tivadar Bognár**, Director General for Digitalisation and Development.

In 2023, a year of change and challenges, the Office has continued to effectively meet its traditionally high professional standards. The HIPO operates according to the requirements of the ISO 9001:2015 quality management standard and the ISO/IEC 27001:2013 information security management standard.

A positive trend is the further **development of electronic administration** for almost all forms of protection. The **trade mark area was again the leader**, with **76% of national trade mark applications received electronically**, up 2% on the previous year, which was already the highest level. It is a major milestone that from September 2023, customers are able to make certain payments for official fees through the VPOS virtual bank card terminal. The 15% fee reduction for electronic applications, which came into force on 1 January 2024, is expected to further accelerate the spread of digital administration.

Hungarian applicants' IP activity **showed positive growth trends in 2023**. For a number of forms of protection (e.g. trade marks, designs), the propensity to file was higher than in the previous year. Despite the awareness-raising measures, the number of Hungarian patent applications filed by Hungarian applicants was lower than in 2022, but the number of international patent applications (PCT applications) of Hungarian origin increased by 10.3%, and the number of European patent applications of Hungarian origin also increased by 3.8%. However, this was the first year in which the overall number of nationally granted and validated European patents in force in Hungary decreased, although the number of requests for validation of granted European patents in Hungary increased again compared to the previous year.

Main trends in industrial property protection activity 2023/2022

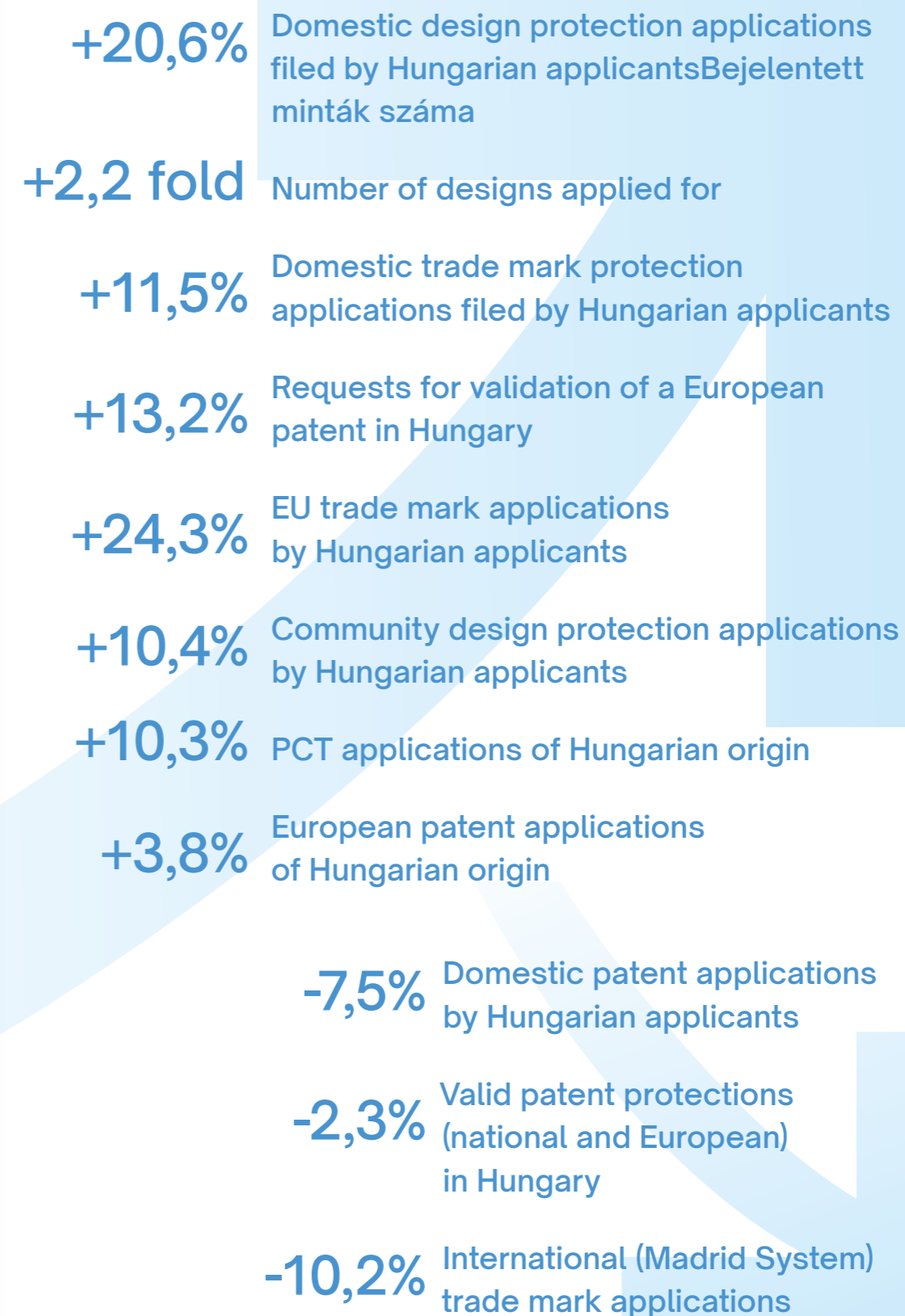

2 | Customer-focused authority

2 | 1 Valid protections in Hungary

IP protections effective in the territory of Hungary are not only indicators of Hungary's competitive economy and R&D activities, but also show **how attractive Hungary's economy is** as a target market for foreign capital and trade.

The economic importance of industrial property protection in Hungary is also due to the fact that all players in the Hungarian market must carry out production, sales and research & development activities in Hungary in compliance with these monopoly rights, otherwise they may be accused of infringement. In addition, the protections granted and in force play a significant role in technology transfer and licensing.

Given the high number of protections in force in Hungary, it is a major effort for economic stakeholders to exercise due diligence in identifying existing monopoly rights. HIPO and the services of patent attorneys provide help in this regard.

2023 was the first year when **the total number of patent protections in force, either nationally granted or validated European patents, showed an overall decrease.**

Evolution of the number of the main valid protections in Hungary (Year-end stock in 2023)

34 023

European patents validated in Hungary

100*

Supplementary Protection Certificates

49 951

National trade mark protections

911

Granted national patents



69 963

International (under Madrid System) trade mark protections

852

Granted national utility model protections

184

Granted national plant variety protections

7 545

Granted national design protections

The number of patents in force at the end of 2023 was 34,934, 2.3% (812) fewer than at the end of the previous year. This was partly due to a slight decrease of 0.15% in the number of European patents in force in Hungary compared to the previous year, which meant 539 fewer European patents in force in Hungary in 2023. On the other hand, the number of nationally granted patents decreased further from 1 184 in 2022 to 911 (by 23%).

The number of valid national trade mark protections was (49 951), it fell by 6.3% (by 3 722 trade marks) compared to the previous year. The number of international (Madrid System) trade marks decreased further by 4.5%, from 73 284 to 69 963. At the same time, the number of European Union trade marks (EUTM), valid also in Hungary, exceeded 2 million.

* Emellett van még 359 olyan megadott SPC, amely az alapszabadalom lejártát követően, a jövőben lesz érvényben.



2|2 Administration in patent matters

3 917

requests for validation
of European patents
in Hungary

Patent applications can be filed under the European Patent Convention (EPC) in 39 contracting states. Foreign patent holders interested in establishing a presence in the Hungarian market typically request the validation in Hungary of their European patents granted by the European Patent Office (EPO). The number of validation requests received by the Office in 2023 increased by 13.2% to 3,917 compared to the previous year.



Number of requests for validation
of European patents in Hungary

Under the Patent Cooperation Treaty (PCT), which is the basis for **international patent cooperation**, patent (or utility model protection) proceedings can be initiated in each of the contracting states by filing an application at a single place in one language. The number of international patent (PCT) applications in 2023 was 272 600. The patent applicant can file a request for extension of the patent to designated countries, including Hungary, at a later stage of the PCT procedure, at the so-called national stage. The number of the actual **requests for national procedure** resulting from earlier PCT designations was low (43).

The number of patent applications filed via the national route was 441.

- include, on the one hand, patent applications of domestic origin and,
- on the other hand, foreign applications filed directly with the HIPO, and
- PCT applications that entered the national phase.

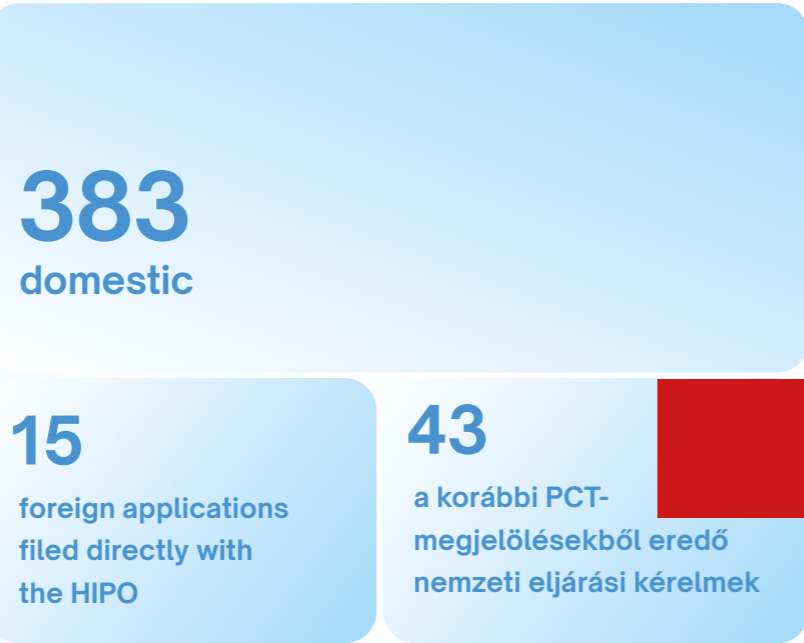

The number of **patent applications filed via the national route** was **441**, 12% (60 applications) less than in 2022. Out of these **383 were of Hungarian origin**, i.e. coming from customers with a seat in Hungary or from residents of Hungary. This is 7.5% (31 applications) less than in the previous year. The number of foreign applications directly filed to the Office decreased from 22 to 15, while the number of procedural requests from earlier PCT designations for national procedure fell from 65 to 43, which is one third of the larger volume of the previous year.

The rate of national patent applications **filed electronically increased to 55%** from the 41% of the previous year. 31% of applications are still received in person, filed to the Office „manually”, but the proportion of applications received in person or through mail fell compared to the previous year.

Over half (54%) of the national patent applications were filed via **patent attorneys**.

Breakdown of national patent applications by origin of applicants



Breakdown of national patent applications by type of applicants

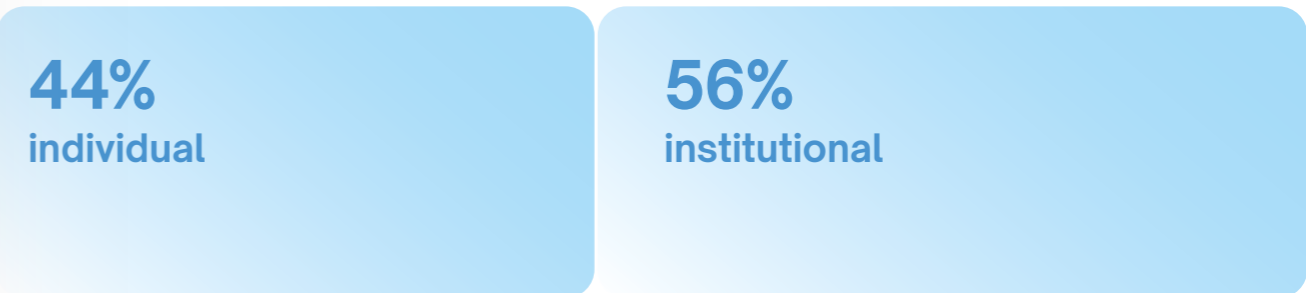

86.8% of nationally filed patent applications were of Hungarian origin, while 13.2% came from abroad. **44.0%** (194) of nationally filed patent applications were so-called **individual applications**, coming from private individuals, while **56.0%** (247) were so-called **institutional applications** from legal entities (e.g. companies, universities, research institutes). The number of applications of Hungarian origin received from individual or institutional applicants both decreased compared to the previous year.

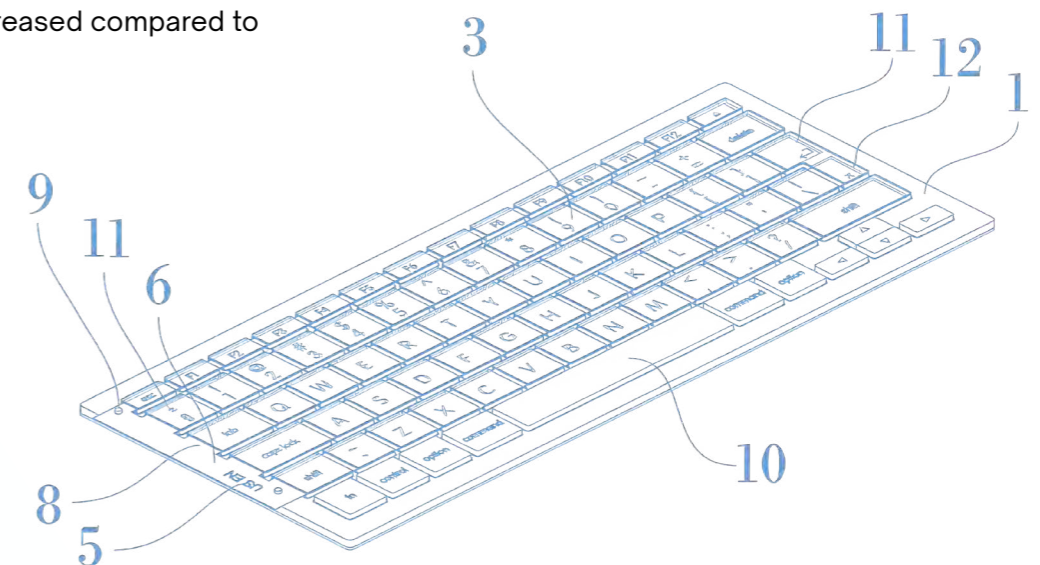

3 809

European patent's
validation closed
proceedings

As far as patents are concerned, the validation procedure of 3 809 European patents were closed by the end of 2023, which is 5.3% more than in the previous year. Of the nationally initiated proceedings for patent protection.

396

novelty search reports

The number of novelty searches carried out during the patent granting proceedings is determined by the number of applications filed in the previous year and still in pending. The Office issued 396 novelty search reports, 27.7% more than in the previous year. Out of these 122 novelty search reports were accompanied by a written opinion, which means that customers requested a written opinion in 30.8% of the cases. 54 of these (44.2%) were requested by customers to be performed in an accelerated procedure. In 10 cases customers requested a written opinion based on the English-language patent description and claims, the possibility of which was opened in 2019.

122 search reports supplemented
with a written opinion

54 search reports supplemented
with a written opinion in
accelerated procedure

10 search reports on the basis
of the English language patent
description and claims

Nemzeti szabadalmi hatósági eljárások

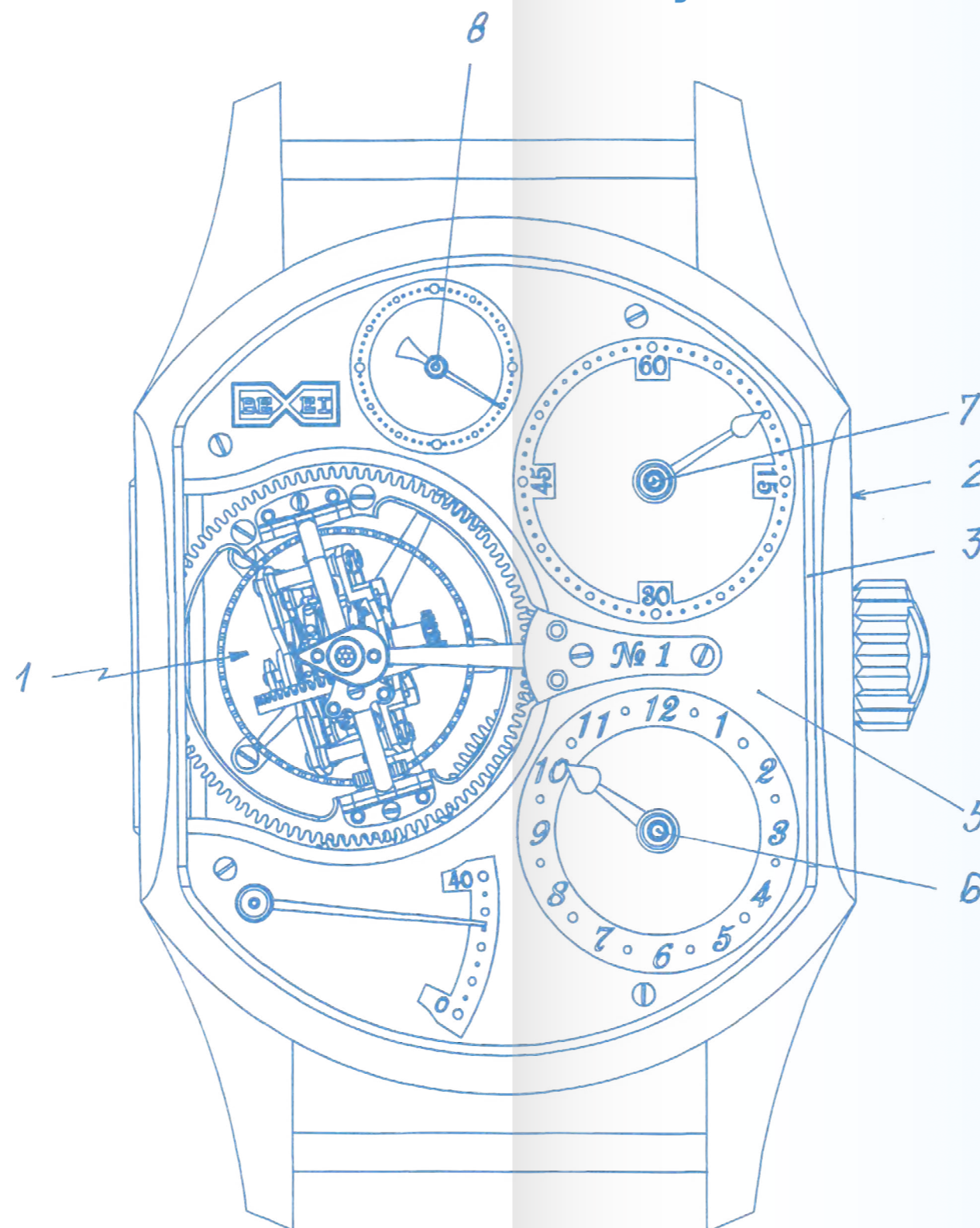

911

valid national
patents

441
applications

285
publications

428
closed proceedings

A nemzeti úton indított, a szabadalmi oltalom megadására irányuló eljárások közül 428 ügy fejeződött be.

Az ügyek 27,3%-a lemondással, 34,8%-a visszavonással, és 5,6%-a a díjfizetés elmulasztásával fejeződött be.

A befejezett szabadalmi ügyek közül 15 bejelentés esetében elutasító döntésre került sor.

864
pending
cases

Az év végén folyamatban levő nemzeti szabadalmi ügyek száma az előző évvel azonos nagyságú, 864 volt.

123
grants

Az eljárást lezáró döntések közül a megadások száma 123 volt, így a befejezett ügyek 28,7%-a zárult nemzeti szabadalom megadásával.

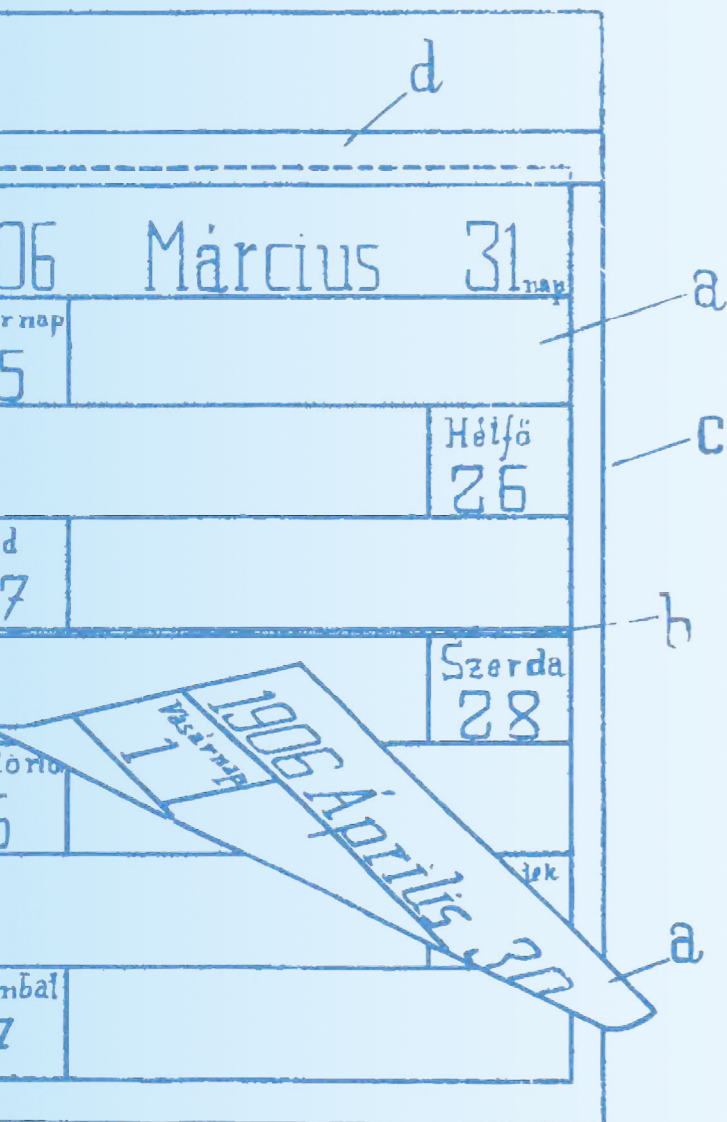

25,0 months

average gross processing period

The average gross processing period of nationally initiated patent applications was 25.0 months, ensuring that the cases were finished in 7.4% (by 2 months) shorter time than in the previous year.

18,3 months

average net processing period

The average net processing period shank (by 2 months) from 20.3 months to 18.3. (The processing time includes the compulsory 18-month waiting time required before publishing a patent.) There is no longer a backlog in any of the areas of expertise, so no further reduction in processing time is expected. Customers did not take advantage of the possibility to request publication earlier than 18 months free of charge to speed up the proceedings. In many cases it is not in their interest to publish the invention prematurely because, they are not yet ready to enter the market.

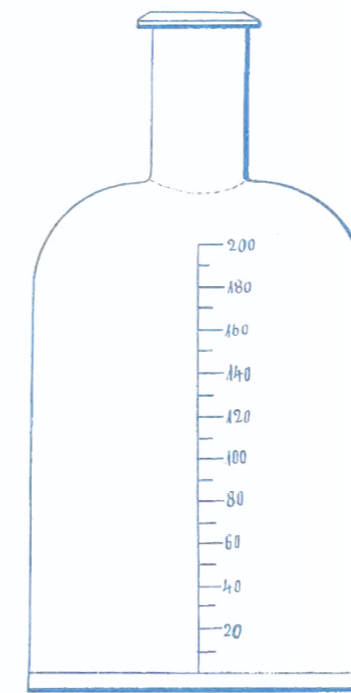

>14 thousand pharmaceutical patents

Among the various technological fields pharmaceutical patents are the number one in terms of both nationally granted and European patents validated. It signals a strong concentration that out of the total number of patents in force in Hungary (national and European), over 14,000 belongs to this sector, followed by other equipment and precision engineering sectors.

- hatályos európai szabadalmak
- hatályos nemzeti szabadalmak
- összes hatályos szabadalom

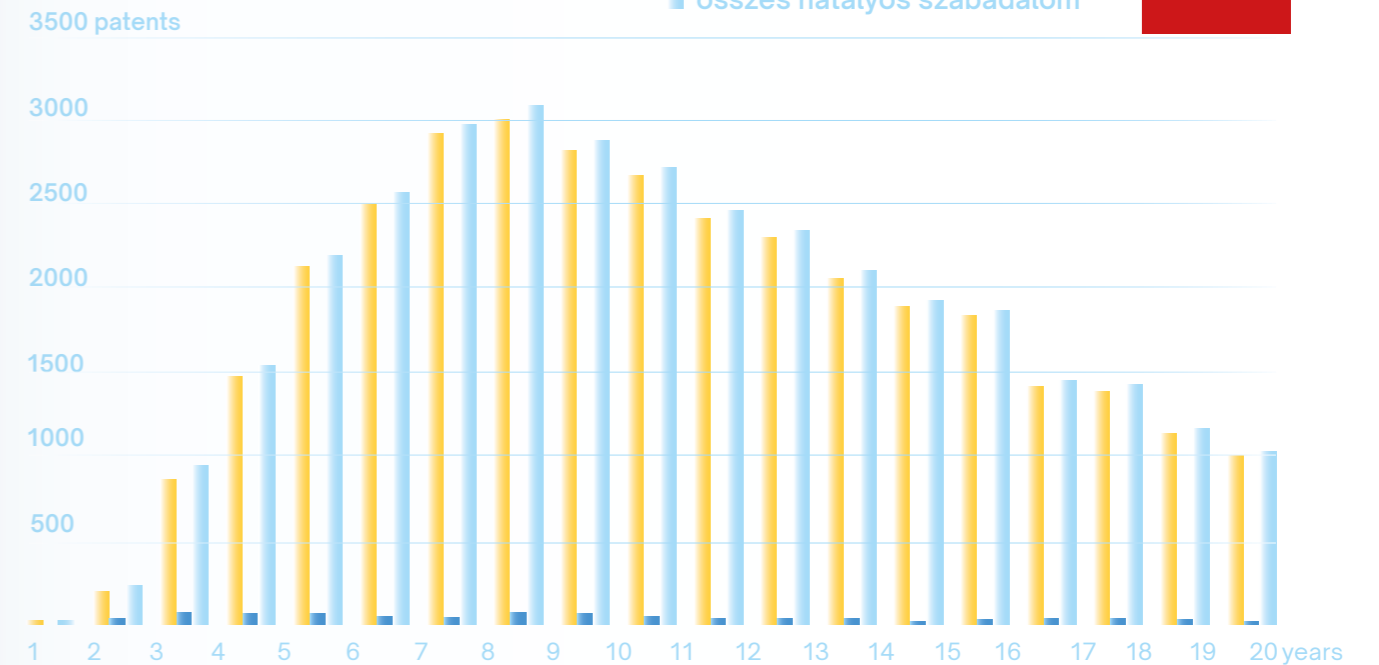

Age pyramid of valid patents in Hungary (granted via the national route and validated European patents)

In terms of the age pyramid of valid patents, the highest number of nationally granted patents are for 9 years (3 083). There are nearly 5000 validated European patents in the 17 to 20 year range, where patent protection will soon expire.

Valid national patents holders in Hungary

97% foreign

TOP10 countries of origin

Breakdown of holders of valid patents (nationally granted or validated European patents) in Hungary by countries of origin

Contrary to the previous year, Hungary does not belong to the TOP10 countries of origin in terms of valid patents, because the proportion of Hungarian patent holders hardly reaches 3%. The top foreign patent holders of patents valid in Hungary are from the US, Germany, Switzerland and Japan.



TOP10 patent holders

Patent holders with most valid patents in Hungary

The toplist of patent holders with the highest number of valid patents in Hungary (granted in a national procedure or validated European patents) is led by large companies with headquarters abroad.



3% domestic

In Hungary, the vast majority, over 97% of patent holders of both nationally granted patents and validated European patents have been foreigners for years. The high proportion of foreign patent holders is related to the sectoral and ownership structure of Hungarian economy and the attractiveness of the economy for foreign trade and foreign capital, as well as the low patent awareness of the stakeholders of the domestic market.

TOP3 domestic patent holders

Domestic patent holders with nationally granted valid patents



TOP5 Hungarian universities

At the end of 2023, Hungarian universities had a total of 91 valid patents in Hungary.



2|3 Administration of utility model protection

A 214 nemzeti úton érkezett használatiminta-oltalmi bejelentés eredet szerinti megoszlása

87,4%
domestic

12,6%
foreign

87.4% of national applications came from Hungarian applicants, while 12.6% of applications came from foreign applicants. 21 foreign applications were filed directly with the Office, and 6 PCT applications entered the national stage. Out of these six PCT applications entering the national stage, the applicant was from Hungary in two cases, while there was a foreign applicant in 4 cases.

TOP4 applications for utility model protection



A használatiminta-oltalmi bejelentések benyújtásának módja

54% 
electronically filed

The rate of electronically filed applications for utility model protection increased to 54% from 40% in the previous year. 4% of applications were received on e-paper, 27% were still filed in person, 12% came through mail, while 3% were filed through the terminal.

27%
in person

12%
mail

4%
e-paper

3%
terminal

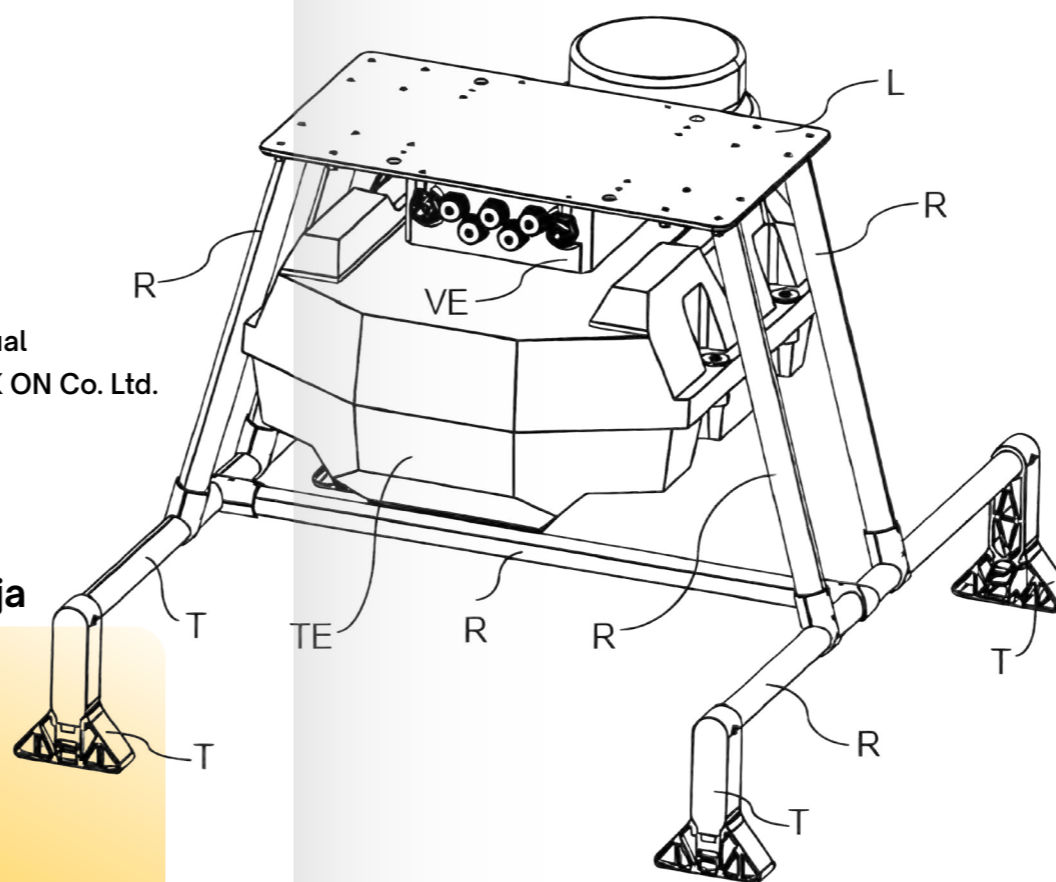

852

valid national utility model protections

At the end of the year 852 utility model protections were in force. According to the age pyramid of utility model protections, in 2023 most of the utility model protections were in their 2nd or 3rd years (118 and 120 protections respectively).

214
applications

In 2023 the Office received 214 applications for utility model protection, which is nearly 3% (with 6 applications) more than in the previous year.

214
closed proceedings

The Office closed 214 proceedings, out of which 134 (62.6%) met the eligibility criteria and were granted protection, 5 applications were refused and 75 cases terminated by withdrawal (due to lack of answer from the applicant, missing fee payment, withdrawal by applicant or internal priority).

134 **5** **75**
grants refusals withdrawals

The average gross processing time of completed cases was 6.73 months, while the net processing time was 3.87 months.

137
pending cases

The number of cases pending at the end of the year was 137, which equals the number of cases at the end of 2022.

2|4 Supplementary Protection Certificates

100
valid
supplementary
protection
certificates

Supplementary Protection Certificates (SPCs) serve as an extension to a patent right of a patent-protected pharmaceutical or plant protection product.

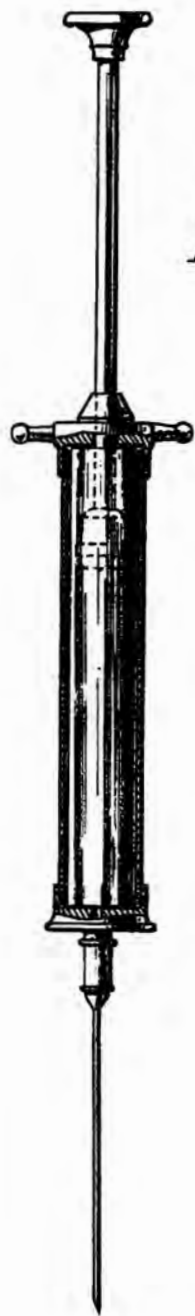

Fig. 2.

45 SPC applications were received by the Office in 2023, which is 10 fewer than in the previous year. The number of supplementary protection certificates in force at the end of the year was 100. In their case, the protection period of the basic patent had expired and the invention was protected by the SPC. In addition to these, in the case of 359 SPCs already granted, the basic patents were still in force, so the inventions were still protected by them. For these, the SPCs will only take effect when the basic patent expires.

From a professional point of view, it was an important task for the Office in 2023 to actively participate in the development of the Hungarian position to be taken at the oral hearing of two preliminary ruling procedures before the Court of Justice of the European Union and in the drafting of answers to the questions previously posed by the CJEU, as well as to elaborate the professional Hungarian position relating to the 4 draft regulations on SPC published by the European Commission.

2|5 Administration activities in the field of plant variety protection

184
valid plant
variety rights

The exclusive use of plant varieties is guaranteed by a special form of protection, plant variety protection.

16
applications

In 2023 the Office received 16 applications for plant variety protection, which is approximately half of the applications filed in the previous year. The periodical fluctuation of the number of applications for plant variety protection is a natural phenomenon, since it takes several years to breed a particular plant variety.

34 23
closed grants
proceedings

During the year, 34 procedures were completed, and protection was granted in 23 cases.

At the end of 2023 the number of nationally granted, valid plant variety rights was 184, 9.5% more than the previous year-end figure. In addition, at the end of 2023 – according to the records of the Community Plant Variety Office (CPVO) – there were 30 943 community plant variety rights in force in the EU, thus also in Hungary, which is 1.2% over the last year's figure.



2|6 Administration in the field of design protection

223

magyar eredetű közösségi
formatervezésiminta-
oltalmi bejelentés

Registered Community Designs (RCD) registered by EUIPO are in force in all the member states of the European Union, and thus in Hungary as well. In 2023 applications for community design protection grew by 10.5%, while the the number of designs included in the applications increased by 6.7%, therefore their quantity exceeded 31 thousand and 98 thousand, respectively.

The number of applications for community design protection filed by Hungarian applicants was 223, reflecting a 10.4% increase compared to the 202 applications filed in the previous year.

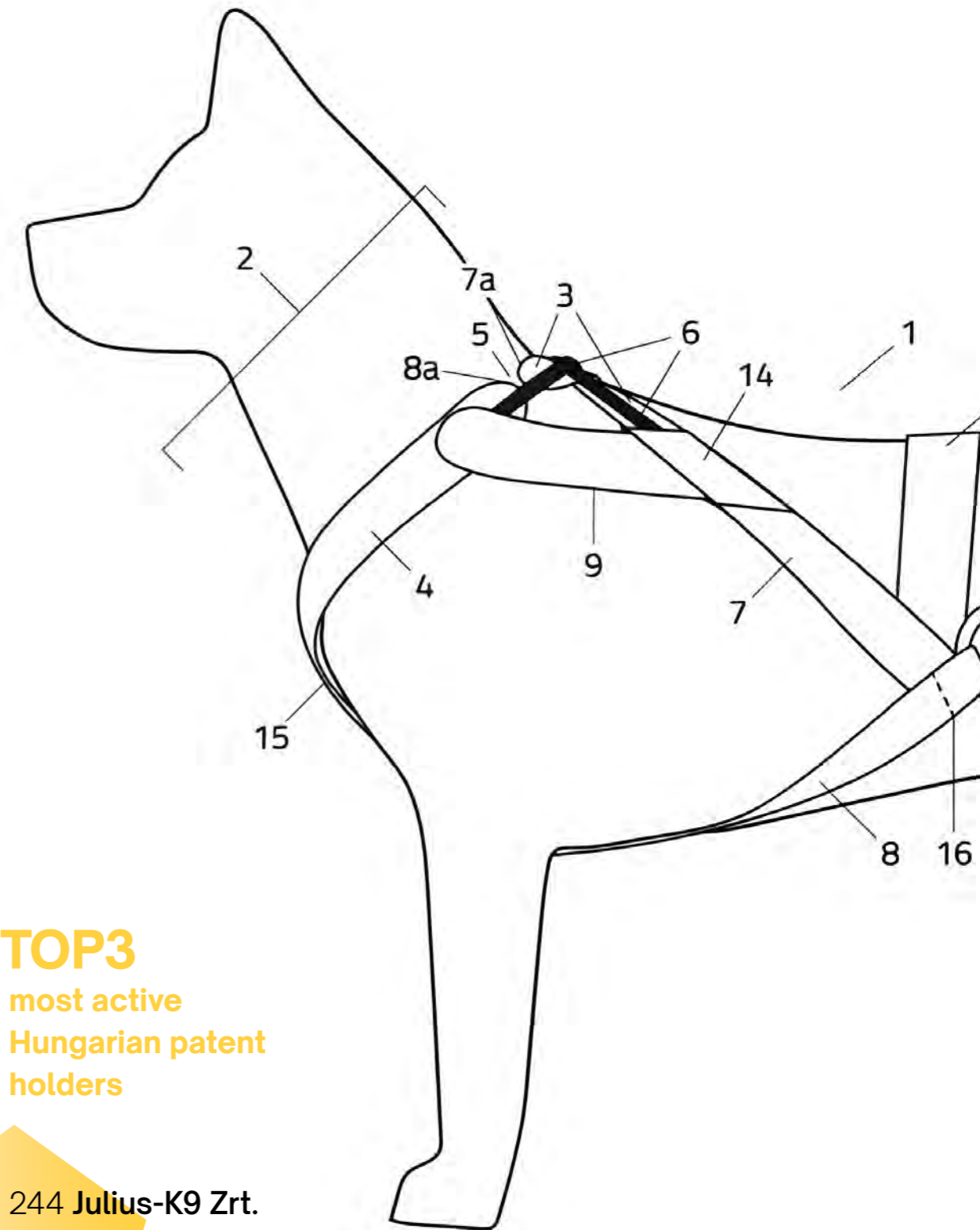

TOP3
most active
Hungarian patent
holders

244 Julius-K9 Zrt.

107 Fireplace Kft.

60 Wellis Magyarország
Kereskedelmi és Szolgáltató Zrt.

Nemzeti úton benyújtott formatervezésimintatípusok

A bejelentők eredet szerinti megoszlása

~100%
domestic

63,6%
individual

36,4%
institutional

TOP3 applicants

10 University of Sopron

6 University of Debrecen

6 Moholy-Nagy University of Art and Design

Almost 100% of design protection applications filed through the national route came from applicants of Hungarian origin (only 1 application coming from a foreign applicant). Applications characteristically came from individual applicants. 63.6% of design protection applications came from individual applicants, 36.4% from institutional applicants. Among the applications, however, the number and proportion of institutional applicants showed a favourable increase.

A bejelentések benyújtásának módja

57%
electronically filed

Similarly to the previous year, 57% of applications were filed electronically. The number of applications filed in person increased by 10% to 29%, while the proportion of applications arriving through mail decreased to 8% and the ones arriving through the terminal to 6%.

29%
in person

8%
mail

6%
terminal

118 applications
424 designs

In 2023 118 national applications for design protection were filed to HIPO, which included 424 designs, that means that each application included on average 3.6 designs. The number of applications filed through the national route increased by 21.6%, while the number of designs included in the applications grew by 2.2% compared to the previous year.

73 closed proceedings
130 designs

In 2023, HIPO closed 27.8% fewer national design protection cases than in the previous year. During the year, the examination of 73 applications were closed, including 130 designs.

Labour shortage in the field during the year contributed to the low number of closed cases and thus of designs examined.

27 grants
44 designs
42 withdrawals
80 designs

Of the 73 applications closed, one third of the designs for which protection was sought were granted, which means that 44 designs were granted. Two applications involving several designs seeking protection were partially granted. According to data, 42 applications were terminated by withdrawal, involving 80 designs.

91 pending cases
399 designs

At the end of the year there were 91 cases pending, including 399 designs.

2106
valid national design protections
7545
designs

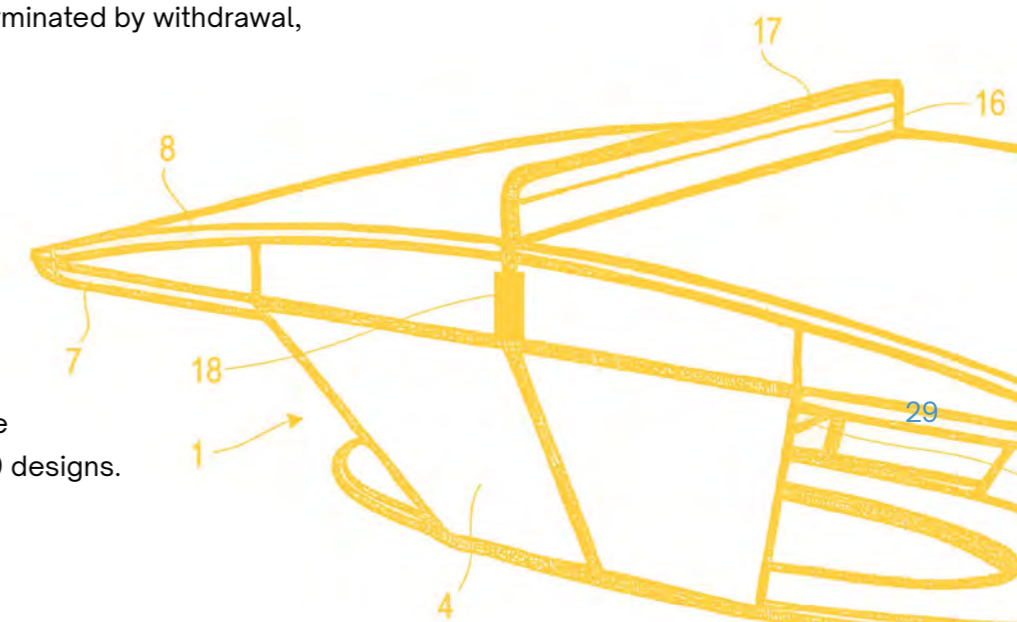

2|7 Trade mark administration

Registered EU trade marks

are also valid in Hungary. The number of EU trade marks applied for in 2023 increased by almost 0.9% to 175,689 compared to the previous year, while the number of registrations was 161,232, 2.3% lower than in 2022. Nevertheless, the stock of EU trade marks valid in Hungary now stands at over 2 million.

International trade mark registration system (under the Madrid Protocol) administered by WIPO, the number of international trade mark applications and of requests for subsequent territorial extensions designating Hungary

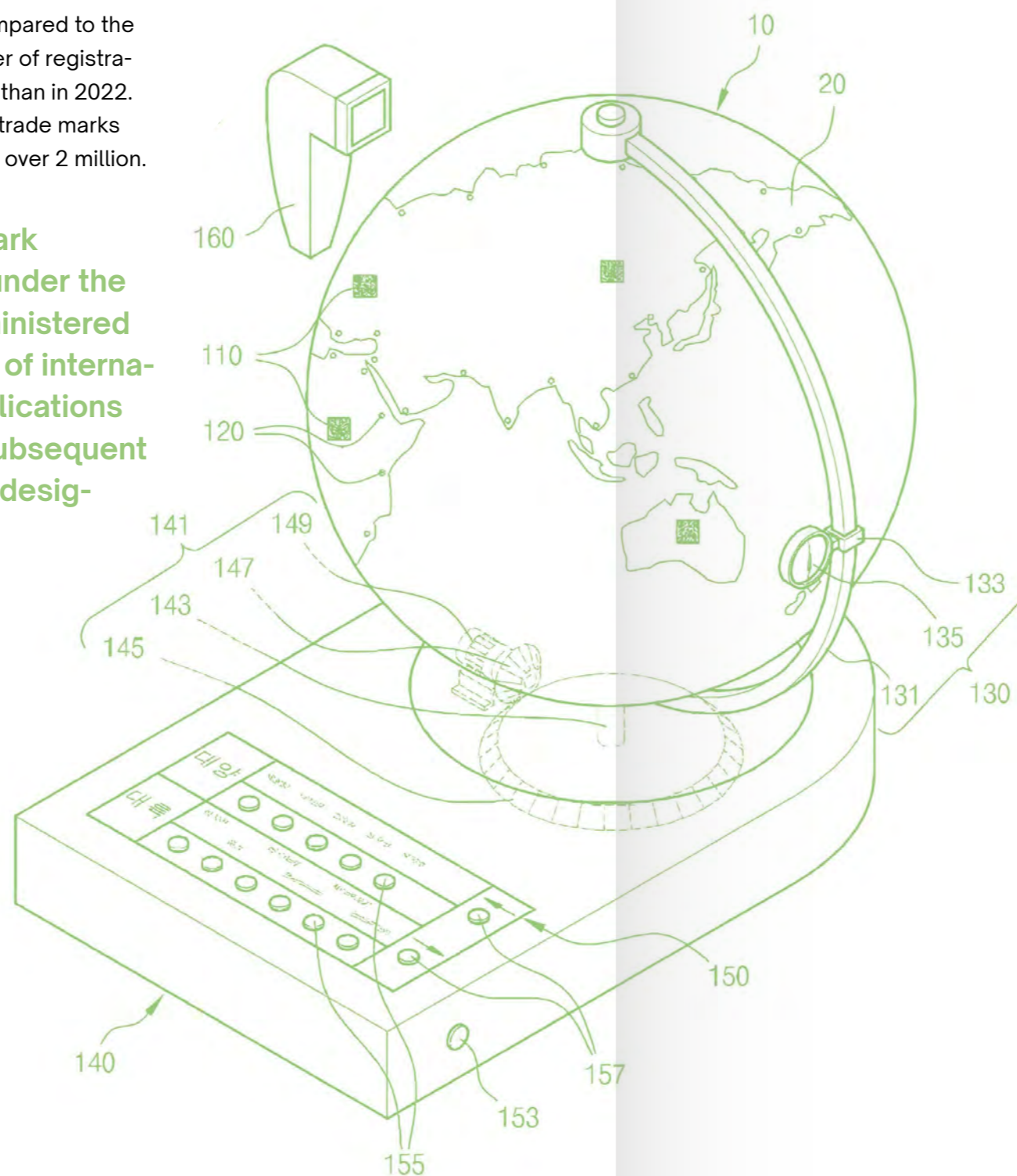

69 963

valid international trade marks

1026

applications, territorial extensions

In 2023, in the international trade mark registration system (under the Madrid Protocol) administered by WIPO, the number of international trade mark applications and of requests for subsequent territorial extensions designating Hungary was 1,026, 10.2% lower than in the previous year.

1031

publications

1 031 international trade mark applications were published in the Gazette of Patents and Trade Marks, an increase of 5.9% compared to the previous year.

1012

closed proceedings

The Office examined 1 012 international trade mark applications and subsequent territorial extensions designating Hungary.

831

registrations (grants)

Of these cases, 831 protections were granted without issuing a provisional refusal, 67 were granted after a partial provisional refusal, 111 international trade mark applications were rejected by the Office, and the proceedings were terminated in 3 cases.

422

pending cases

422 international trade mark applications were pending, 53 more than the previous year. As a designated office, the HIPO succeeded in further reducing pendency times compared to the previous year: currently the pendency time is 15.85 weeks, almost 2 weeks shorter than the previous year.

Hungarian trade mark applicant activity

3 399

HIPO
Nationally filed trade mark applications of domestic origin

1 063

EUIPO
EU trade mark applications of Hungarian origin

The activity of trade mark applicants of Hungarian origin abroad started to increase. The number of EU trade mark applications filed by Hungarian applicants in 2023 was almost a quarter, 24.3%, higher than in the previous year, with the number of applications rising to 1 063 in 2023, compared to 855 in 2022. In 2023, 862 EU trade marks of Hungarian origin were registered in the EU, an increase of 18.6% (135 trade marks) compared to the previous year (727).

221

WIPO
International (Madrid System) trade mark applications of Hungarian applicants

The HIPO received a total of 221 international (Madrid System) trade mark applications and requests for territorial extension from Hungarian applicants, as well as 17 other requests to be transmitted to the WIPO International Bureau.

TOP5

Hungarian trade mark holders who were the most active TOP5 EU trade mark applicants in 2023:

114 **URSA SALGOTARJAN GLASS WOOL CLOSE CO.**

97 **EGIS Gyógyszergyár Zrt.**

75 **Zwack Unicum Nyrt.**

69 **MOL Nyrt.**

64 **Richter Gedeon Nyrt.**

Nemzeti úton benyújtott védjegybejelentések

A nemzeti védjegybejelentések megoszlása a bejelentők származása szerint

92%
domestic

[3399]

8%
foreign

[297]

A nemzeti védjegybejelentések megoszlása a bejelentők jellege szerint

Of the trade mark applications received nationally, 59% were filed with the Office by representatives.

63,9%
institutional

36,1%
invidual

TOP5

National trade mark applicants

100 **Richter Gedeon Nyrt.**

70 **EGIS Gyógyszergyár Zrt.**

22 **magánszemély**

16 **PQ Partners Limited**

15 **M-RTL Zrt.**

Nemzeti védjegybejelentések benyújtásának módja

76% electronically filed

Of the forms of protection, electronic administration made the greatest inroads in the area of national trade mark applications. In 2020, the proportion of electronic applications increased sharply and has been steadily increasing since then: in 2023, 76% of trade mark applications (2 819 applications) were filed electronically, compared to 73.5% in the previous year.

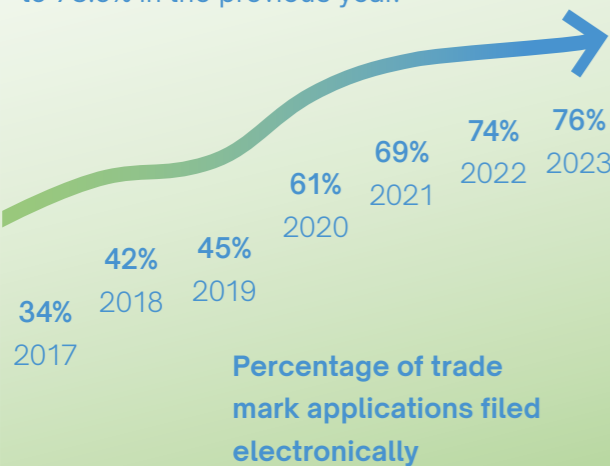

24% on paper

While only 24% of applications were filed on paper (e.g. by post, in person, via terminal).

53 accelerated procedure

Customers have the possibility to speed up the administrative process through the so-called accelerated procedure and special accelerated procedure. During the year, 53 requests for accelerated procedure and 112 requests for special accelerated procedure were received, bringing the total number of applications examined by the Office under this procedure to 165.

112 special accelerated procedure

Average pendency time for national trade mark applications

We succeeded in further reducing the average gross pendency time for the national trade mark registration proceedings compared to the previous year: the processing time was 18 weeks or 4.5 months in 2023, and so it has been less than 6 months in every year since 2020.

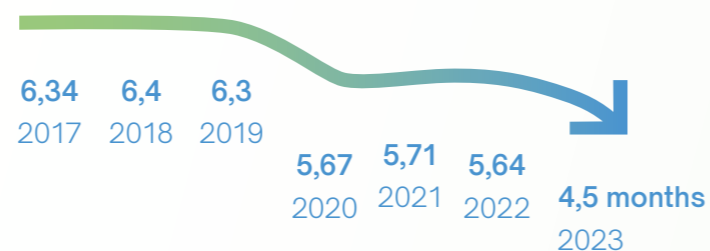

3 696

national trade mark applications

The number of trade mark applications filed with the HIPO nationally was 3,696 in 2023, an increase of 363 applications, or 10.9%, compared to the previous year. In addition, 4 applications for guarantee marks and 3 applications for collective marks were filed with the Office. During the year, 36 conversion requests were also received.

2 677

publications

The number of publications in 2023 was 2 677, 10.3% fewer than in the previous year.

3 600

closed proceedings

The Office closed 3 600 cases in 2023. Registrations continued to dominate among the closed proceedings with 79%: in 2023, the Office registered 2 826 national trade marks. The number of refusals was 55 and the number of terminated cases was 719.

2 826

registration (grants)

55 719

refusals terminated cases

2 062

pending cases

The Office had a stock of 2 062 pending cases at the end of the year.



49 951

valid national trade marks

TOP10

Breakdown of valid national trade marks by country of origin of right holders

36 138 Hungary

5187 United States of America

1015 Germany

995 United Kingdom

808 Switzerland

798 Japan

572 The Netherlands

483 France

366 Republic of Korea

287 China

The number of valid national trade marks at the end of the year was 49 951, down 6.9% on the previous year. Of the nearly 50,000 valid trade marks in the national trade mark register, 72% were owned by Hungarians and 28% by foreigners. As in previous years, the majority of trade mark owners were based in the US, Germany and the UK.

national trade marks by origin

92% domestic

8% foreign

national trade marks by applicants

63.9% institutional

36.1% individual

TOP10

national trade mark right holders

1104 HU Richter Gedeon Nyrt.

978 HU Egis Gyógyszergyár Zrt.

277 HU Médiaszolgáltatás-támogató és Vagyonkezelő Alap

235 HU Mediaworks Hungary Zrt.

224 HU TV2 Média Csoport Zrt.

197 HU TEVA Gyógyszergyár Zrt.

169 NL Unilever IP Holdings B.V.

155 HU Zwack Unicum Nyrt.

153 HU Szerencsejáték Zrt.

151 US The Procter & Gamble Company

Two major Hungarian pharmaceutical companies, Richter Gedeon Nyrt. and EGIS Gyógyszergyár Zrt., topped the list of right holders of the most valid national trade marks also in 2023. Among Hungarian higher education institutions, Corvinus University of Budapest has the highest number of valid national trade marks (15), followed by the University of Pécs (14) and ELTE (13).

15 Corvinus University of Budapest

14 University of Pécs

13 ELTE

TOP3

national trade mark right holder universities

3500 trade marks

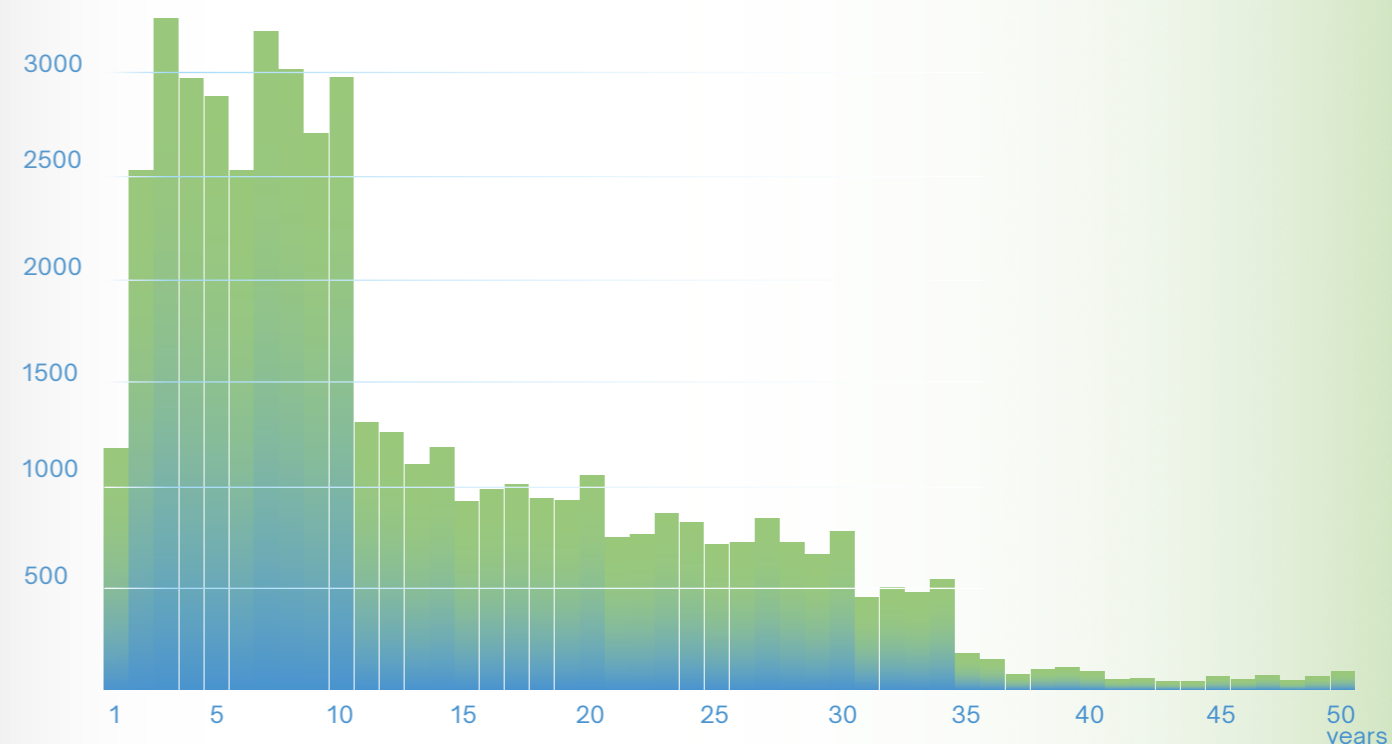

The age pyramid of valid national trade marks

At the end of 2023, on the age pyramid of valid national trade marks the number of trade marks in the 3rd and 7th year is the highest. In the first 10 years, the number of valid trade marks is significantly higher (2 to 3 thousand per year), while in the following 10-year cycles, which imply the renewal of trade mark protection, the number of valid trade marks per year decreases. In 2023, a total of 2 641 trade marks were renewed.

Budapest 65642. 1939 április 1.
I. G. Farbenindustrie Aktiengesellschaft,
Frankfurt a.M.
Vállalkozás: gyógyszerészeti gyár.
Aspirin
Áru: gyógyszerészeti készítmény.
Eredetileg lajstromozva: 1899 ápr. 19. 6013. sz. alatt.

1932/6.B.

APENTA SPLITS
SPARKLING



~70
100+ years old trade marks

The national trade mark register contains 70 trade marks that are more than 100 years old. The oldest trade mark is the "ODOL" sign, filed by Panadol GmbH. with the filing date of 26 July 1895. Other holders of trade marks over 100 years old include for example the signs of GRUPA MASPEX Sp.z.o.o. Sp.k. 'APENTA' in 1899, Bayer 'ASPIRIN' in 1899, Aesculap AG. 'AESCULAP' in 1900, Valvoline LLC 'VALVOLINE' in 1902 and Johnson & Johnson 'LISTERINE' in 1903. The Hungarian trade mark holder with the oldest trade mark is Richter Gedeon, whose sign „TONOGEN” was entered in the register with the filing date of 19 November 1902., i.e. it is 122 years old in 2024.



2|8 Geographical indications

A geographical indication which may be used to identify the geographical origin of marketed products must be based on a verifiable link between the quality characteristics of the products and their region of origin. The protection ensures that right holders are able to take action against anyone who makes unauthorised use of the indication.

In the course of the year, 88 applications for international appellations of origin designating Hungary and 40 international geographical indications were received by the HIPO.

33 Hungarian
1477 European Union

Geographical indications for agricultural products and foodstuffs

According to the eAmbrosia database, the number of registered EU geographical indications for agricultural products and foodstuffs at the end of 2023 was 1 477, of which 33 were of Hungarian origin. In 2023 "Lajta cheese" and "Szabolcsi apple" were registered.

38 Hungarian
1629 European Union

Geographical indications for wines

The number of EU geographical indications for wines reached 1 629, of which 38 were of Hungarian origin.

16 Hungarian
248 European Union

Geographical indications for spirit drinks

The number of EU geographical indications for spirit drinks was 248, of which 16 were of Hungarian origin. In 2023, "Nagykörűi cseresznyepálinka", "Sárréti kőkenyepálinka" and "Borzag pálinka" were registered.

28 Hungarian
1315 WIPO

Oltalom alatt álló nemzetközi eredetmegjelölések száma

According to the WIPO database, 28 of the 1,315 international appellations of origin in force under the Lisbon Agreement were of Hungarian origin (e.g. [Herend](#), [Kalocsa](#), [Szeged](#), [Tokaj](#)).

2|9 Contribution of patent attorneys, representatives

Az ügyvivők, képviselők fontos szerepet töltenek be – az ügyfelek nemzetközi képviselete mellett – a hazai bejelentők SZTNH előtti képviseletében is. A nemzeti úton benyújtott bejelentések esetében minden oltalmi formánál jelentős részarányt képviselnek az ügyvivők (képviseelők) közreműködésével benyújtott bejelentések.

Az elmúlt 10 év statisztikai adatai alapján készült egy összesítés a hazai bejelentők által a hivatalhoz benyújtott szabadalmi bejelentések számáról, amelyeket a hivatali ügyfelek szabadalmi ügyvivő segítségével tettek. Az eredményekből látható, hogy 300 hazai szabadalmi bejelentés megtételénél nagyobb szabadalmi ügyvivői kapacitás sem az elmúlt években, sem jelenleg nem állt rendelkezésre. Ahhoz, hogy a minőségi hazai szabadalmi bejelentések száma növekedjen, szükség van a meglévő, de folyamatosan elöregedő szabadalmi ügyvivői kapacitások fejlesztésére.

Erre a részre ennyi szerepel a fordításban:

In addition to international applications, a significant proportion of applications filed nationally are filed with the assistance of attorneys (representatives) for all forms of protection.

A szabadalmi ügyvivők által képviselt hazai szabadalmi bejelentések és az összes hazai szabadalmi bejelentések száma

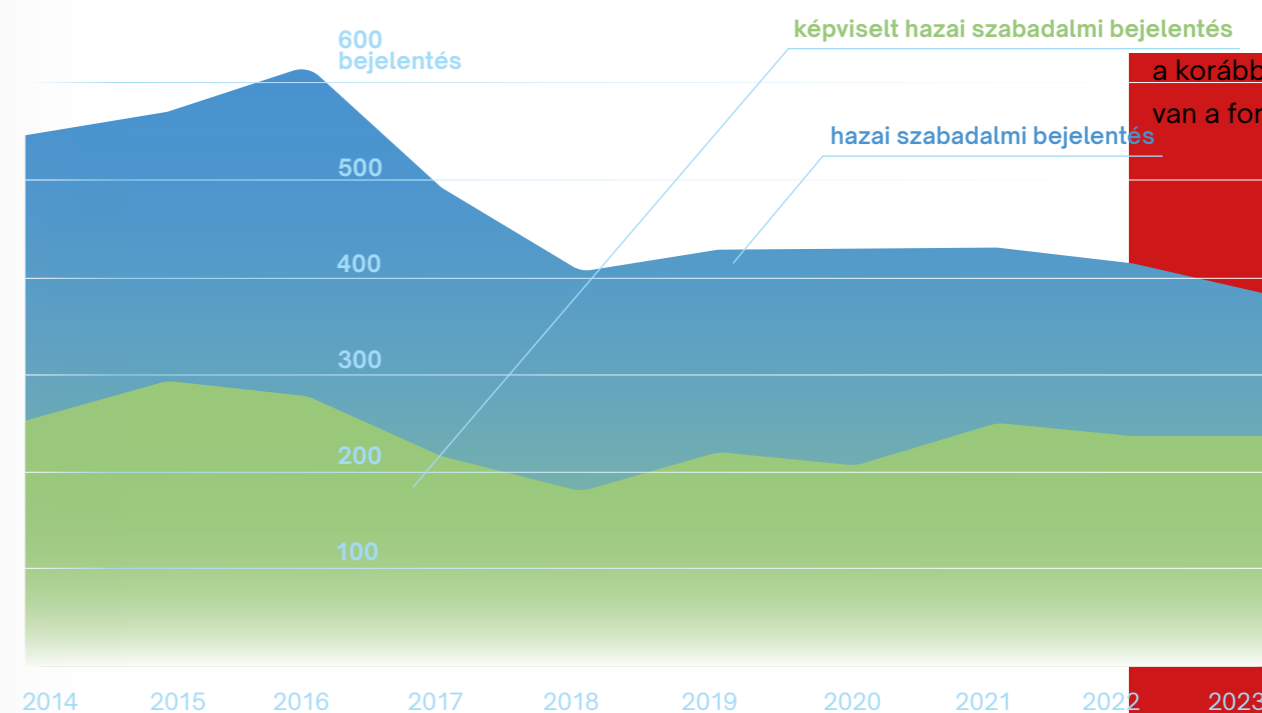

a korábbi diagram van a fordításban

3 | Preparation of laws

The Office has played a proactive role in preparing the drafting or amending of legislation on the protection of intellectual property.

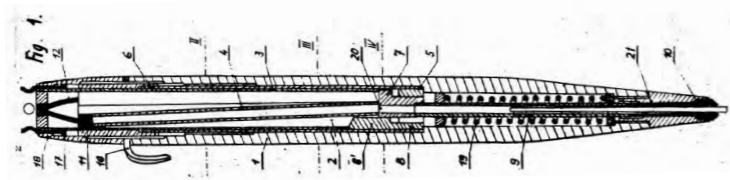

The HIPO contributed to the elaboration of the draft of the Act on the amendment of certain laws necessary to promote the economic exploitation of innovation and scientific results, which was prepared within the framework of the **János Neumann programme**. Act XLI of 2023 on the amendment of certain laws necessary to promote the economic exploitation of innovation and scientific results contains, inter alia, amendments to Act XXXIII of 1995 on the Protection of Inventions by Patents, Act XLVIII of 2001 on the Protection of Designs and Act LXXVI of 2014 on Scientific Research, Development and Innovation. The Office has also been involved in drafting and commenting on the related legislative amendments at the level of regulations.

The Office has prepared a draft proposal for the amendment of Decree 19/2005 (IV.12.) on administrative service fees of the Ministry of Economy and Transport, which reflects the fact that the Hungarian State Treasury has joined the instant payment system, and has prepared the necessary legislative amendments for receiving payments via the Internet (VPOS).

The rules of the EU regulations on **de minimis aid** are to be applied to enterprises and research institutions when they benefit from the new fee reductions for small and medium-sized enterprises, higher education institutions and research centres provided for in Article 115/O (1a) of the Patent Act. The treatment of these benefits as de minimis aid creates an excessive administrative burden for both the Office and the customers, therefore it is expected that the take-up of these benefits will fall short of the initial expectations.

The HIPO participated in the preparation of the amendment of the **design protection regulation**. From 1 January 2024, the design protection regulation will be amended in several points on the basis of Act XLVIII of 2001 on the Protection of Designs, Act XXXIII of 1995 on the Patent Protection of Inventions and Decree 19/2005 (IV. 12.) of the Ministry of Economy and Transport. The Office will no longer carry out ex officio the examination of compliance with the requirements of novelty and individual character, nor will it produce a search report, and from 1 January 2024 a protectability opinion will be introduced for customers.

The Office prepared a concept for the revision of the **utility model protection regulation**, which was adopted, and which is supported by the Ministry of Culture and Innovation (MoCI) and the Ministry of Justice (MoJ).

One of its **legislative tasks in the field of copyright** has been to monitor the legislative changes in the framework of the **EU copyright reform**. The most significant legislative work was the participation in the amendments to the tariff approval procedure in Act XCIII of 2016 on the collective management of copyright and related rights.

Artificial Intelligence (AI) is a topic of great general interest, and there is a lively debate around the world on how to manage its results from a creative industry perspective. The draft regulation establishing harmonised legislation on artificial intelligence and amending certain EU legislative acts (AI Act) was amended on 14 June 2023 to include sections on copyright, following a proposal by the European Parliament. The HIPO commented on the positions regarding the copyright-related sections of the AI Act.

A priority Council working party dossier is the negotiation of issues related to the diplomatic conference on the adoption of an international convention on intellectual property, genetic resources and associated traditional knowledge, within the framework of the Intergovernmental Committee on **Genetic Resources, Traditional Knowledge and Folklore** of the World Intellectual Property Organization, for which the Office is actively involved in the elaboration and representation of the Hungarian position.

The Office continuously monitors intellectual property cases before the Court of Justice of the European Union (CJEU) and processes the decisions, which are published in a searchable CJEU judgement search database on the HIPO website.

4 | Copyright authority

In the context of the tasks relating to the supervision and registration of collective management organisations (CMOs), the Office ensures the maintenance of an online register of CMOs. Its competence extends to the registration of independent rights management organisations and also the authorisation of representative collective management activity.

At the end of 2023, the following associations and companies were listed in the register available to the public on the Office's website (<http://kjk.sztnh.gov.hu>):

Collective rights management organisations



Independent rights management organisations



The Office carried out **27 registration procedures** following applications from the CMOs. Supervision of collective rights management and independent rights management is subject to a **supervisory procedure** once a year, in accordance with the rules on official controls. The annual supervisory procedures will be carried out by the HIPO after the submission of the annual reports of the CMOs. In doing so, the Office examined the current operation of the CMOs and whether the conditions for registration had been met continuously during the period under review, in addition to verifying compliance with the calls made in the 2022 supervisory procedure. Of the 13 annual supervisory proceedings initiated in 2023, 9 proceedings ended with a notification (order) and 4 proceedings required a decision as a supervisory measure. The Office carries out the tasks related to the administration and registration of the supervision fees payable by the collective and independent management organisations.

The Office was involved in the procedures for approving the tariffs of CMOs. Within this framework, by the deadline of 1 September 2023 set by Act XCIII of 2016 on the collective management of copyright and related rights, 6 collective management societies sent 21 tariffs, the same number as in the previous year, as an initiative to launch the consultation procedure. The Minister of Justice rejected 17 tariffs on 27 November 2023 and rejected the remaining 4 on 21 December 2023, which is without precedent in the history of the supervision of CMOs.

Orphan works are works that are difficult to use because the right holder of the work is unknown or in an unknown place and the user cannot obtain permission from the author to use them lawfully. In order to address this situation, the HIPO has become the authority responsible for authorising the use of orphan works. During 2023, 7 applications for authorisation to use orphan works were submitted, 57% of which were for architectural works. The Office granted authorisation for use in 5 of these procedures.

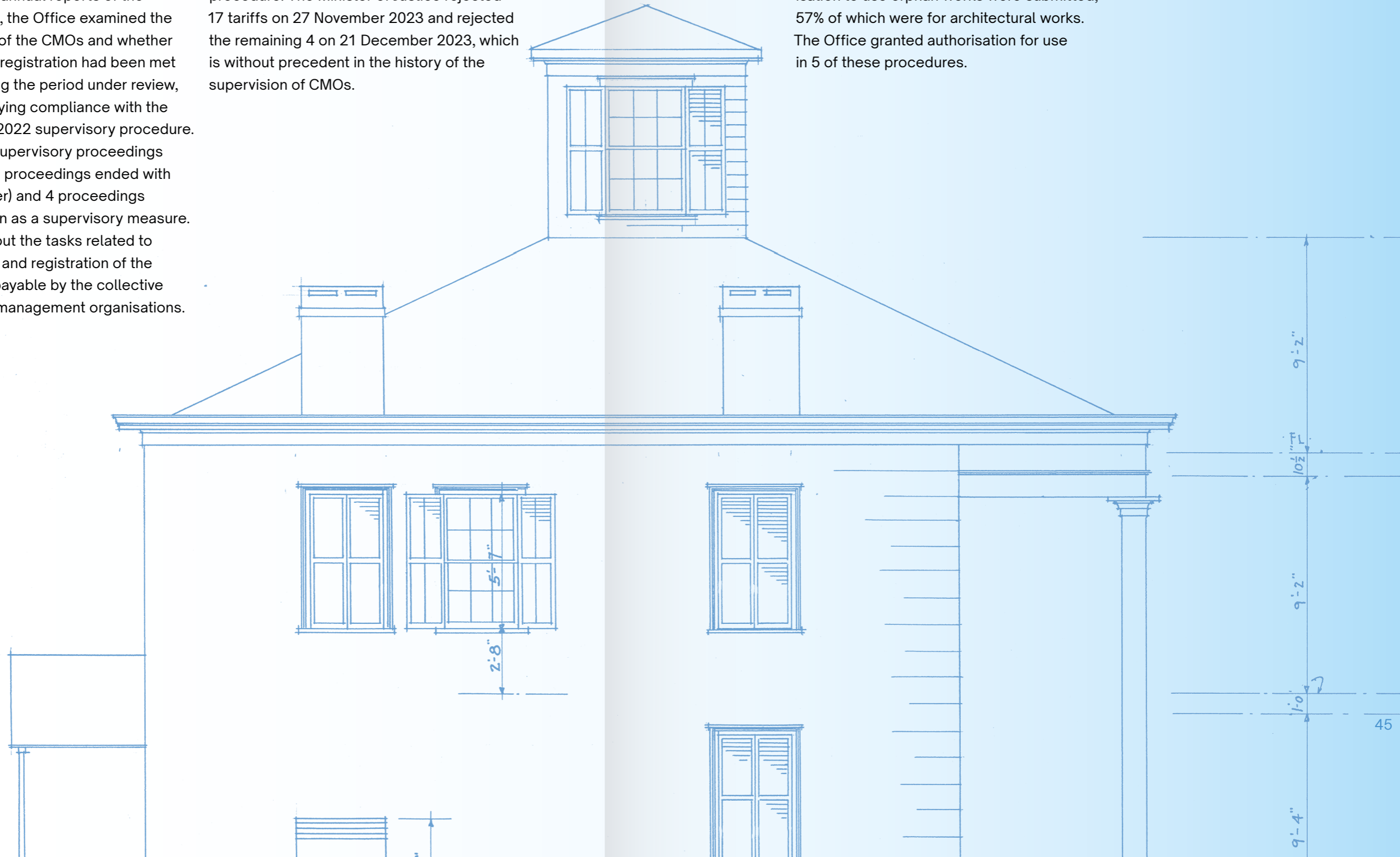

5 | International IP diplomacy

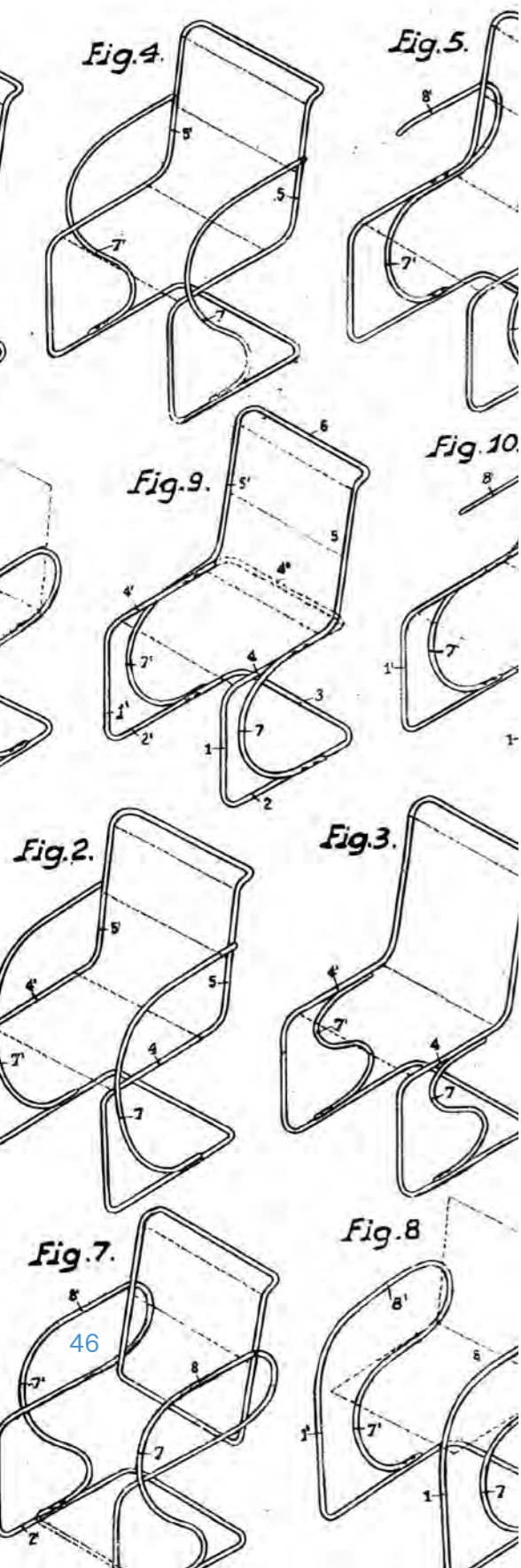

A The HIPO's **international cooperation activities are closely linked to international organisations dealing with intellectual property**. The Office cooperates actively with the European Patent Organisation, the Council of the European Union, the European Union Intellectual Property Office (EUIPO), the World Intellectual Property Organization (WIPO) and the Visegrad Patent Institute (VPI), and strengthens bilateral relations with its partner offices.

The HIPO, with the assistance of the delegations led by the President of the Office, has effectively carried out its tasks in the Administrative Council in exercising the rights and fulfilling the obligations of a Member State under the European Patent Convention. The staff of the Office participated in the work of the Select Committee of the Administrative Council, the Budget and Finance Committee, the Patent Law Committee, the IT Working Group and in the training courses of the European Patent Academy (EPO).

On 17 October 2023, a delegation from the EPO visited Budapest. The main objective of the meeting was to determine the future directions of cooperation between the two offices, in particular in the field of IT.

The commemoration of 50th anniversary of the European Patent Convention (EPC) was attended by a delegation of the President of the HIPO on 5 October 2023. In the margins of this event, a bilateral meeting was held with EPO President António Campinos.

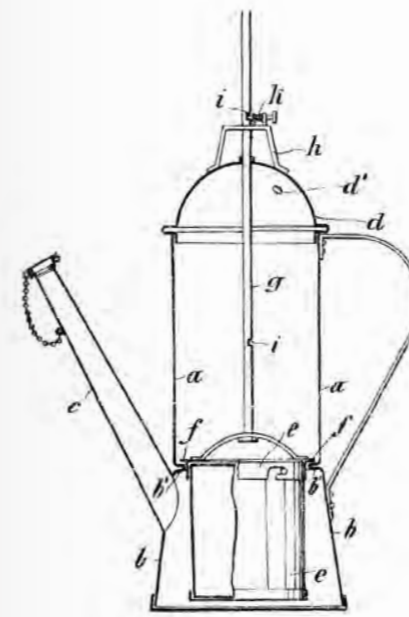

Within the framework of the three-year Bilateral Cooperation Agreement with the EPO for the period 2021-2023, the Office undertook to implement 9 projects.

The Agreement on a **Unified Patent Court** (hereinafter "the UPC Agreement") entered into force on 1 June 2023 and the UPC started operations. Regarding the ratification of the Agreement, the Hungarian government decided that 1) for the time being Hungary does not intend to ratify the UPC Agreement; 2) Hungary intends to maintain its observer status in the UPC's Administrative and Budget Committees; 3) Hungary will implement the ongoing trainings of the UPC Training Centre, but will not participate in the organisation of further training sessions; 4) Hungary will monitor the functioning of the UPC and the impact of its case-law.

Trainings at the UPC's Judicial Training Centre in Budapest took place in line with the previous commitment. The three types of training, held between January and March 2023, consisted of 20 training days and were attended by 256 judges and administrative staff, 325 participants from 14 countries. The trainings were successfully organised and conducted by the HIPO in cooperation with the Permanent Representation in Brussels, which is testified by the positive feedback from participants and international organisations.

In 2023, the HIPO staff continued to participate **in the Working Party on Intellectual Property of the Council of the European Union** and in other EU events. Intensive cooperation with the **EUIPO** continued. The senior officials of the HIPO participated in the meetings of the EUIPO Management Board and Budget Committee, and its expert staff participated in liaison meetings on trade mark law, design and cooperation, as well as in working group meetings and the EUIPO Boards of Appeal regional seminar in Warsaw.

On two occasions, on 30 January and 5 September, the staff of the HIPO and EUIPO held an online meeting (Virtual Technical Meeting) to review the main issues of technical cooperation between the two offices.

21 projects will be implemented under the EUIPO-HIPO cooperation agreement. A priority task for the HIPO is the replacement of the internal administrative registration system with the EUIPO Back Office system and its adaptation to the domestic legal environment. As a result, a number of online and face-to-face meetings were held between the EUIPO and the HIPO staff in 2023 and presentations were made.

On 30 May 2023, the EUIPO and the HIPO organised a joint online webinar entitled "The Importance of Intellectual Property for SMEs", where experts from the two offices gave presentations on EUIPO IP protection support, the SME Fund, the importance of obtaining trade mark and design protection, and a Hungarian startup shared its experiences in this field.

On 25 October 2023, an online webinar entitled "IP4YOU" was jointly organised by the HIPO and EUIPO, where experts from the two offices gave presentations on important IPR-related topics for IP lawyers and other professionals.

The HIPO represented Hungary in the international cooperation within the framework of **WIPO**, participated in the committees, working groups and major events of the world organization.

The 64th Series of Meetings of the Assemblies of the Member States of WIPO took place in Geneva from 6 to 14 July 2023, and was attended by a delegation led by the President of the HIPO. The President of the HIPO held successful negotiations with Director General Daren Tang. They exchanged views on the possibility of introducing IP management training in Hungary, for which WIPO intends to provide technical support, and on the V4 project on IP-backed financing. The President of the HIPO also held talks with Deputy Director General Ken-Ichiro Natsume, which resulted in the signing of the WIPO-HIPO Data Exchange Agreement in November.

It is a success of IP diplomacy that the General Assembly of the Budapest Union for the International Recognition of the Deposit of Microorganisms elected Szabolcs Farkas as its Vice-Chairman.

On 28 February 2023, WIPO and the HIPO organised a "Regional Webinar on the Calculation of Damages for IP Infringements" with the participation of more than 300 experts.

One of the main areas of international cooperation in 2023 was the **strengthening of bilateral relations**. The President of the HIPO visited, and received delegations from, intellectual property offices in several neighbouring countries to promote cooperation. In this way, relations between the Czech Republic, Slovakia, Poland, Slovenia, Albania and the V4 were further strengthened.

The **Visegrad Patent Institute** (hereinafter "the VPI"), based in Budapest, was established by the four Visegrad countries as an intergovernmental organisation for patent cooperation. It acts as an International Search Authority (ISA) and an International Preliminary Examining Authority (IPEA). In 2023, the Administrative Board was chaired by Patrycja Czubkowska, Vice-President of the Polish Patent Office.

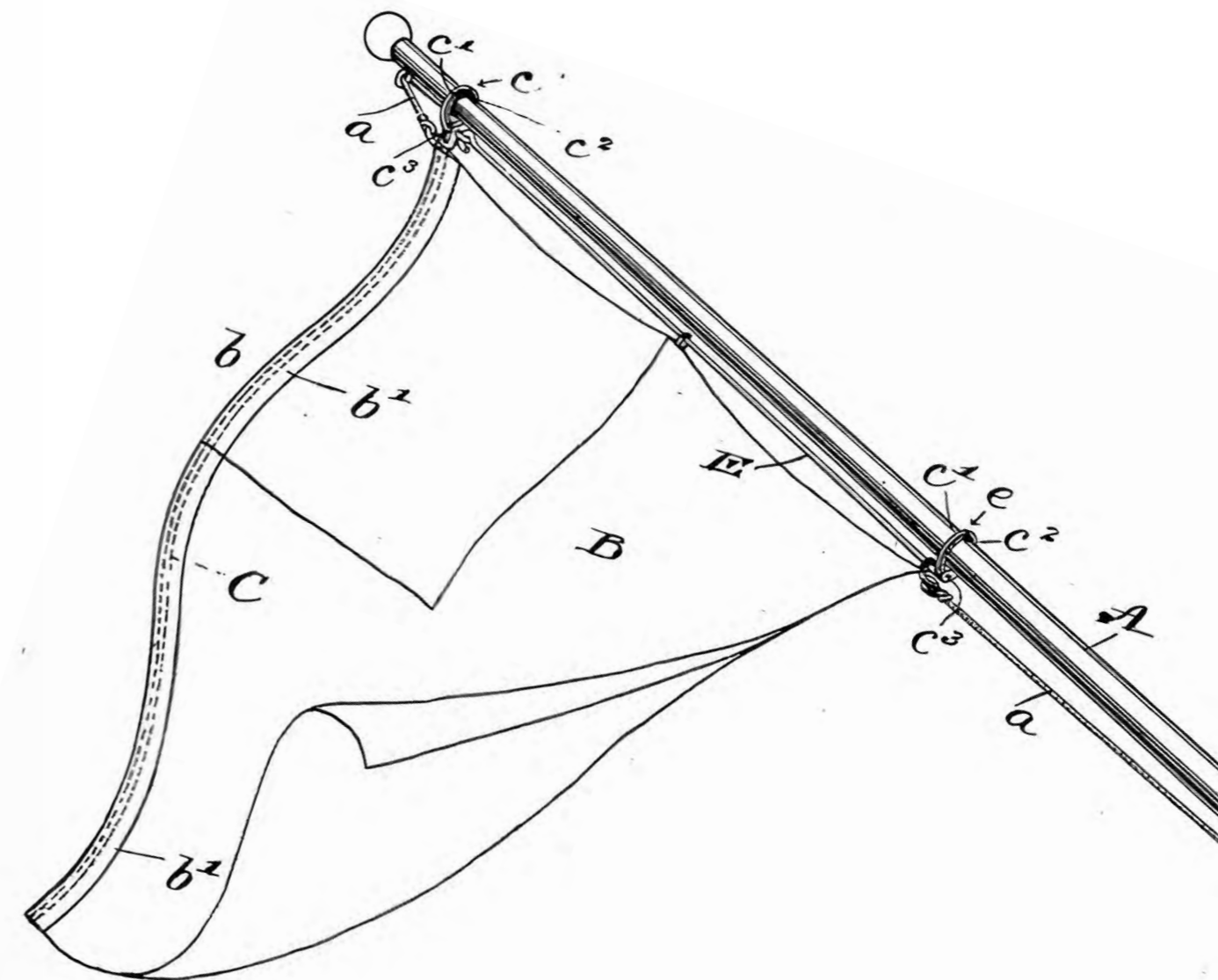

In 2023, a total of 89 requests for International Search Reports (ISRs) and 3 requests for International Preliminary Examination Reports (IPERs) were received by the VPI. More than two thirds (69%) of applications were made in national languages (Hungarian, Czech, Polish) and 31% in English.

The VPI also accepts international patent applications from citizens of Lithuania and companies and other organisations established in Lithuania from 1 June 2017 and Serbia from 1 September 2020. In 2023, 6 Serbian applications were received, for which the international search was undertaken by the HIPO, the Industrial Property Office of the Czech Republic and the Polish Patent Office.

From 1 October 2023, the HIPO launched **its global patent search services** on a commercial basis, comprising two types of new search services, the **novelty search** and the **novelty search with preliminary patentability report**. Global patent search services are available to customers regardless of their country of origin. The new services have the advantage of providing expert answers on the novelty and patentability of an invention or technical solution in just 4 weeks, before a patent application is filed.

6 | Focus on attitude shaping

Attitude shaping and awareness raising are HIPO's headline targets in the field of protection of intellectual property. Significant target groups are enterprises (with special regard to SME's and startups) and higher education institutions. HIPO is engaged in raising awareness among them on the importance of intellectual property and obtaining protection of IP rights, which may help them secure competitive advantage and prestige, as well as an increase in market value.

6 | 1 Awareness raising among enterprises

In 2023 HIPO addressed SME's through two important messages or offers:

IP Scan
102 ↗
applications

Free IP Scan service and financial assistance (SME Fund and "IPARJOG" tender) proved to be effective messages. In 2022 HIPO registered altogether 63 IP Scan applications, while in 2023 this number nearly doubled, reaching 102 applications by the end of the year, out of which 54 reports have already been completed.

SME Fund
306 ↗
applications

While in 2022 there were 107 Hungarian applications for EUIPO's SME Fund, in 2023 this number almost tripled, reaching 306.

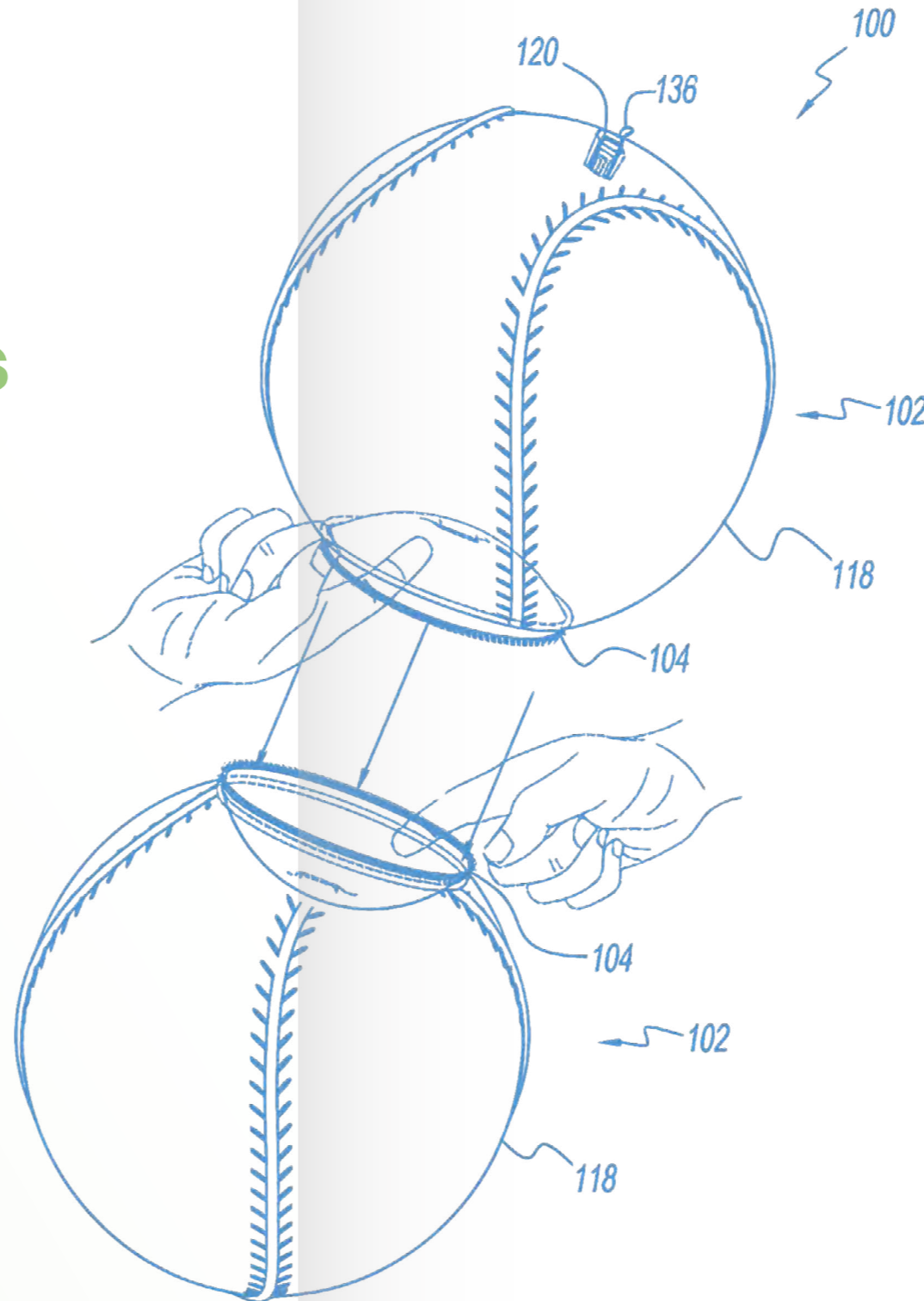

"Value from an idea – IP Compass for SME's"

office publication

HIPO's publication entitled Value from an idea – IP Compass for SME's, issued in 2023 to give advice specifically to SME's in IP protection questions, helps enterprises navigate the various IP protection mechanisms, including practical advice. It shows the importance and benefits of obtaining protection through successful Hungarian examples in three key industries – food, construction and sports.

PATLIB

IP info points

HIPO has effective agreements with 16 county chambers of commerce and industry and PATLIB centres of 6 renowned Hungarian universities to operate IP info points.

Konferenciák és szakmai együttműködések

HIPO was involved in a large number of professional, awareness-raising and attitude shaping events. Through Piac és Profit conferences, organised involving local chambers of commerce and industry, HIPO reached around 1100 SME's with its awareness-raising presentations. HIPO cooperates with several professional (industry and advocacy) organisations, bringing it closer to the Hungarian startup scene, or to certain SME's through individual industry players.

6|2 IP education

There is a long track record of educational cooperation with the country's top universities.

IP Day – Knowledge Utilisation at the Highest Level

The conference "IP Day – Knowledge Utilisation at the Highest Level", jointly organised by the Hungarian Intellectual Property Office, the National Research, Development and Innovation Office and the Ministry of Culture and Innovation on 26 October 2023 for universities, research institutions and technology transfer offices, was a great success. The aim of the event was to create a common platform for these institutions on issues related to management of intellectual property asset awareness raising and education.

Intellectual property diagnostics

As a pilot project, HIPO prepared for Óbuda University a large-scale intellectual property diagnostics survey, summarising in detail the IP protection options, tools and steps that could be of benefit to them.

"Copyright for Everyone"

As part of the basic level copyright curriculum, the 2nd edition of HIPO's publication entitled Copyright for Everyone was published in 2023. The book presents the development of copyright law, the rights of authors, and explains copyright law through dozens of cases and practical examples.

3248

participants
at courses

In 2023 there were 3 248 participants at courses organised by HIPO, 70% participating through state-of-the-art e-learning.

Higher education

9 faculties of 7 higher education institutions offered a one-semester IP protection course in the form of a stand-alone subject, while IP protection course was offered connected to other subjects in 6 more universities.

Courses

The basic, intermediate and advanced level courses on industrial property and the basic and intermediate level courses on copyright, as well as the targeted courses organised by HIPO for various organisations have traditionally been playing a significant role in IP knowledge sharing and they form an important part of out-of-school training.

Intellectual property protection trainings organised in co-operation with HIPO broken down by form of training

70,1%
e-learning 2277
students

E-learning in the field of IP is gaining popularity in universities. While in 2021, 758 students took an exam in HIPO's E-learning curriculum, in 2023 three times as many, 2,277 students of higher education institutions participated in this form of training.

16,8%
targeted courses

6,9%
professional trainings

5,6%
courses in
higher education
institutions

0,6% students of Ujvári János
diploma competition)

The subjects Intellectual Property Protection, as well as Innovation Management and Industrial Property Rights Protection were taught through e-learning at the University of Debrecen, University of Pannonia, the Hungarian University of Agriculture and Life Sciences, University of Nyíregyháza and Eszterházy Károly University, as well as among students participating at the János Ujvári diploma competition. The increase in the number of students justified HIPO's decision taken earlier to start developing e-learning curriculum. HIPO completely refreshed the e-learning curriculum in the field of industrial property rights protection.

Courses on intellectual property

given in cooperation with HIPO at higher education institutions

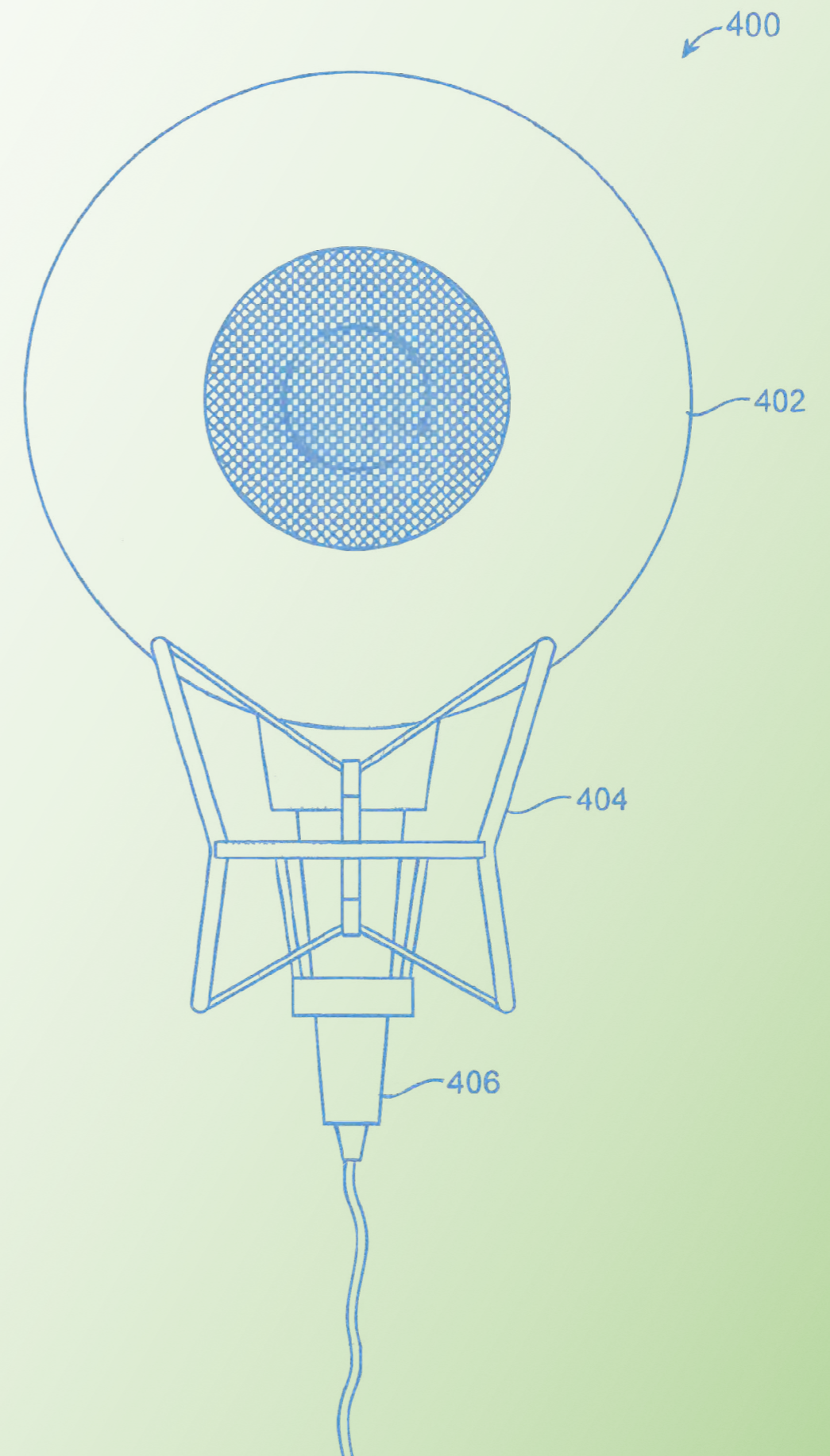

6|3 In the service of customers

The Office's central customer service provides general information on questions concerning the protection of intellectual property in person, through telephone and in writing, both in English and in Hungarian. Queries are increasingly wide-ranging; there are a large number of queries about international conventions and the acquisition of rights abroad.



Number of queries received by the customer service

In 2023, the customer service received 19 469 queries, which is 7.8% higher than in the previous year (18 053), and even higher than in the year of opening after the pandemic (2021).

Queries received by the central customer service broken down by method

66%
by phone

Among the methods of requesting information, queries by phone played a prominent role both in terms of proportion and number. The number of queries received by phone has been continually growing since 2018. Two thirds of queries took place through telephone, which means that nearly 12.5 thousand such queries were received by the Office.

14%
in-person

Parallel to this, the number of in-person queries was halved by the pandemic, only starting to rise again afterwards, in 2022. In 2023 the year over year increase in the number of in-person queries was 14.4%.

15%
by e-mail

Despite this, the number of e-queries has been almost constantly increasing since 2019: in 2023 the customer service received 2 824 e-mail queries, which is 14.9% over the previous year's figure. The number of queries arriving via post, fax or mail remains low (863).

5%
by fax or mail

Breakdown of queries received by the central customer service by field of interest

It is common experience that customers turning to the central customer service inquire about several areas of expertise at the same time.

36,1%
trade marks

Similarly to previous years, trade marks accounted for the largest proportion of all requests for information (36.11%). In recent years, the number of queries on trade marks has slightly fallen, possibly due to the increasing availability of customer-friendly information material on the website, such as videos supporting trade mark applications.

21,5%
provision of data

Information on databases is an important area of customer service activity (21.5%), which includes all queries relating to domestic and foreign databases, electronic services and the website, as well as assistance in using domestic and foreign industrial property rights protection databases.

3,2%
design

3%
utility model

0,5%
R&D qualification

4,6%
general information

6,4%
copyright

10,9%
patent

13,8%
other

In line with international standards, in addition to the cost-free customer service information, HIPO also offers its customers advanced level intellectual property services. Two types of trade mark and seven types of patent search services are available to the customers.

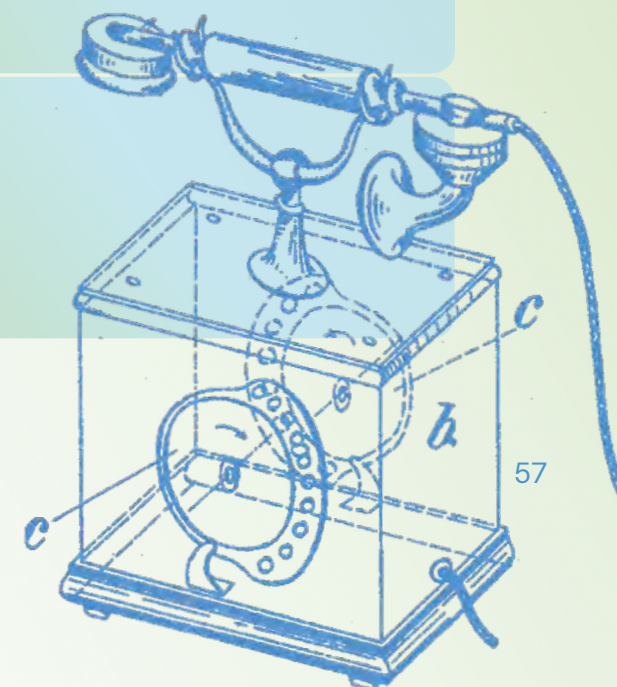

IP Scan

In 2023 HIPO's priority was to ensure that its former IP diagnosis service, renewed as IP Scan, should reach as many customers as possible. The aim of the cost-free advisory service is to provide users, mainly SME's, with as complete a picture as possible of the opportunities and risks of exploiting their intellectual property. As a result of the successful promotion campaign, the number of businesses requesting the service nearly doubled compared to the previous year.

Website

HIPO's website equally serves both potential customers less familiar with IP issues and experienced professionals with easily understandable technical information. The high level of interest in the website is demonstrated by the fact that in 2023, 333,000 uniquely identifiable users visited the website 570,000 times, the number of pages downloaded exceeded 2.4 million html pages and the volume of data downloaded exceeded 2.28 TB.

Electronic administration and filing services

Through the website users can access such useful electronic administration and filing services as **e-administration**, **e-search**, **e-register** and **e-inspection of documents**. It is also possible to file electronically all types of industrial property protection applications as well as requests for the validation of European patents and for registration in the voluntary register of works.. Customers may use the **TM e-Filing** system suitable for submitting trade mark applications, the **TM View** system suitable for electronic trade mark searches, the **Design View** database containing designs protected in the European Union and the **GI View** database containing geographical indications. More and more customers use the opportunity of e-administration.

Number of requests for registration in the voluntary register of works

The central customer service is responsible for the voluntary registration of works and other subject matters covered by Act LXXVI of 1999 on Copyright. The number of requests exceeded 1000 in 2023. This was 8% (70 works) more than the 931 requests in the previous year. There is the possibility of full electronic administration of the voluntary register of works, but the majority of clients still prefer the in-person office routine. As a result of the daily digitalisation process, the entire documentation is available electronically on the Office's e-search platform.úton elérhető a hivatal e-kutatási felületén.



Gazette for Patents and Trade Marks

The Gazette for Patents and Trade Marks, published electronically and available free of charge on the Office's website, is a classic tool for sharing official information on industrial property protection, authenticated by electronic signature.. A large number of professionals read the publication, in 2023 the Office registered over 157 thousand html pageviews and over 250 000 pdf downloads.

Industrial Property and Copyright Review

The Industrial Property and Copyright Review, containing high quality professional studies on IP protection, is published bi-monthly as a stand-alone periodical. The full text is immediately available and can be downloaded electronically from the Office's website.

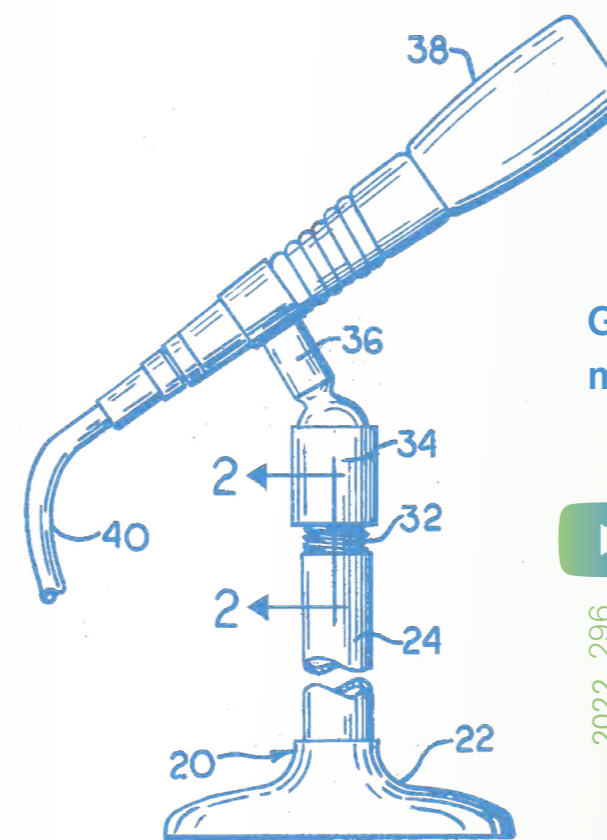

Growth of social media followers

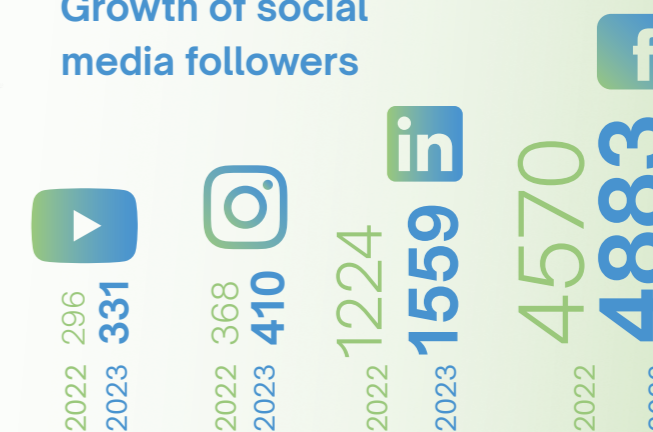

8
press
events

31
press
releases

15
major interviews
with the President
and the Vice-
Presidents

750+
news items

100+
radio and television
interviews and
reports

HIPO's external communication

The aim of HIPO's external communication is to make HIPO's activities as widely known as possible, and to educate businesses and researchers so they understand that greater economic benefits can be gained from IP protection. With the campaign entitled **IP Heroes** HIPO intends to target various sectors. In 2023 the construction industry was in focus, in cooperation with two well-known companies (**Barabás Téglakő and ingatlan.com**) that have been successfully and consciously protecting their IP for years. During the year, 8 press events, 31 press releases, over 15 major interviews with the President and the Vice-Presidents, more than 750 news items and over 100 radio and television interviews and reports helped communicate the Office's activities to the public. In the field of sponsored content, the Office has a permanent column on **Jazzy Radio's "Millásreggeli"** programme. HIPO's presence in the social media has been further strengthened.

6|4 IP events and prizes

HIPO plays a leading role in organising IP-related professional events, as well as in recognising outstanding creators and creative communities.

Ányos Jedlik Prize

In keeping with tradition, one of the most prestigious prizes of the Hungarian Intellectual Property Office, the Ányos Jedlik Prize, was awarded on 17 March 2023 at a ceremony held at the National Museum, in recognition of outstandingly successful inventive activity, as well as industrial property protection work of outstanding quality and efficiency. The following people were awarded the Ányos Jedlik Prize:

László Fésüs, Széchenyi Prize-winning physician, biochemist, full member of the Hungarian Academy of Sciences, former rector of the University of Debrecen;

Zoltán Kovári, Hungarian and European patent attorney, Managing Director of Kovári Patent and Trade mark Office Ltd;

Levente Ondi, chemical engineer, Managing Director of Ximo Hungary Kft;

Gábor Stépán, Széchenyi Prize-winning mechanical engineer, university professor, full member of the Hungarian Academy of Sciences.

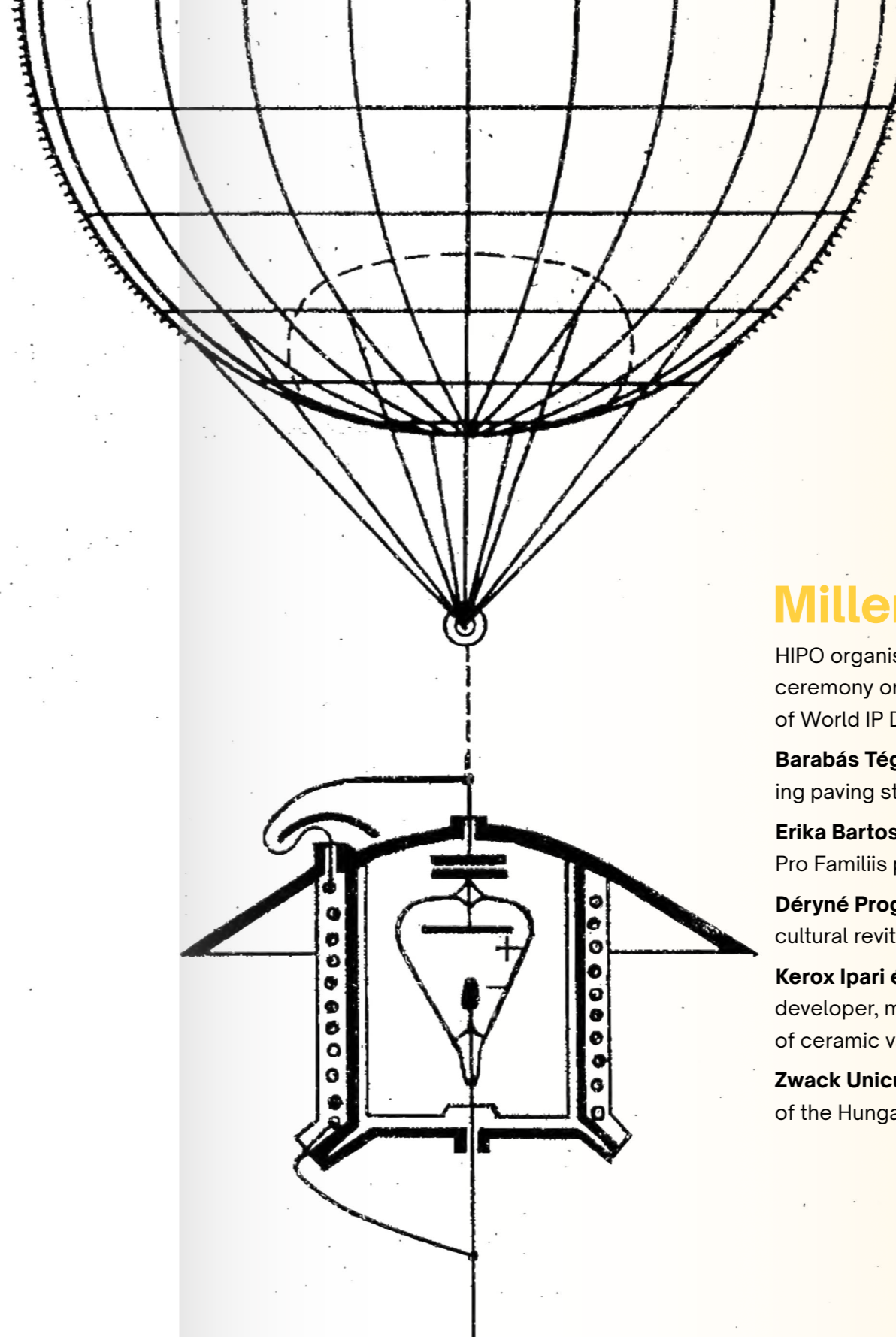

Millenium Prize

HIPO organised the Millenium Prize-award ceremony on 26 April 2022, on the occasion of World IP Day. Winners of the award were:

Barabás Téglakő Kft., engaged in manufacturing paving stones,

Erika Bartos, story writer winning the Pro Familiis prize,

Déryné Program, at the forefront of the cultural revitalisation of the regions,

Kerox Ipari és Kereskedelmi Kft. developer, manufacturer and distributor of ceramic valves,

Zwack Unicum Nyrt., one of the flagships of the Hungarian spirits industry.

7 | Efficient management

7|1 Digitalisation, Information Technology

Preliminary Declaration of Settings for Electronic Administration

1) Introduction of automatic data request from the Preliminary Declaration of Settings for Electronic Administration (Rendelkezési Nyilvántartás), continuously initiating data requests from the Ministry of Interior's system starting as of June 8 2023.

Proof of Concept

The project reporting working group of the Back Office project established the data storehouse structure serving reporting requirements along the Proof of Concept structure accepted earlier, and set up the data collection mechanism for statistical flash reports. The work on establishing the format of the statistical flash report has started and the testing period has been launched.

Front office

In April 2023 HIPO started the analysis of the future Front Office service with the aim to decide which international software package to introduce. On the basis of the analysis, the decision was made to introduce EUIPO's Front Office software package, including the User Area and Customer Services modules. The program package chosen needs to cover all types of IP protection. The expected date of introduction of the package is planned for the beginning of 2025.

Website modernisation

In January 2023 HIPO started preparation works for the website modernisation project, which was finally launched at the end of October. The project started with infrastructure planning, information security and branding tasks.

Centralised Human Resource Records

HIPO set up the technical conditions for introducing the Centralised Human Resource Records and data migration started to the central system (Ministry of Interior). Parallel to this process, it turned out that the software will not replace the functions of the software – Nexon – currently used by HIPO, including the digital approval of holidays and the digital record of hours worked and on holiday. The system went live in June 2023.

Virtual Point of Sale (VPOS)

In the first half of the year HIPO prepared the concept and then planned and started to introduce the Virtual Point of Sale (VPOS) system enabling e-payment by card. The development process finished in September and the service went live.

CTI software

Relating to the Back Office project, but independently of it, the introduction of the CTI software with the aim to replace the TM/DS View started, in order to implement the data exchange with EUIPO in the Blockchain mechanism based on HyperLedger Fibre. The data service relating to trade mark-related data started on 4 December 2023. The data service relating to design data is still under development.

Electronic document inspection service

In the autumn of 2023 HIPO assessed the possibility of relaunching the electronic document inspection service. After assessing the needs, the function that enables going public parallel to taking the measures was developed. Further preconditions of making the documents public were reviewed, and it was established that documents with electronic signature may not be published.

Information Technology and Information Security

The Information Technology and Information Security section of the Office introduced 96 changes in 2024 in the area of information technology assets and services.

Service Desk

The Information Technology area is characterised by the data derived from the Service Desk system: out of the 4 560 requests received in 2023 4 458 were solved, 123 were refused. Feedback from users shows that the monthly satisfaction rate was always close to 5 on a scale of 1 to 5. Out of the 45 requests for development, 14 were closed.

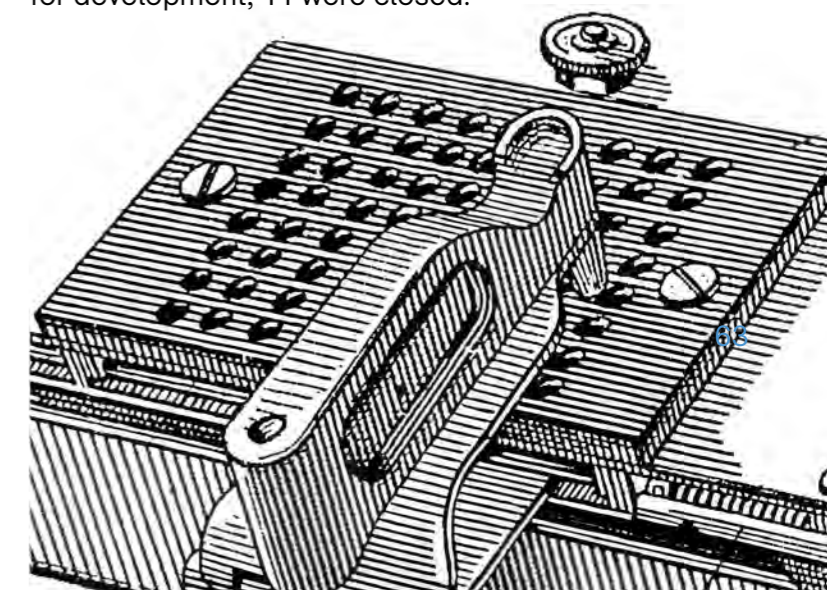

7|2 Financial management

In the Act on Public Finances, the Hungarian Intellectual Property Office is listed under the Ministry of Culture and Innovation as Title 3 of Chapter XX.

HIPO covers the costs of its operation from its own revenues, including the administrative service, maintenance and renewal fees received at rates set by ministerial decree, the international procedural fees and convention-based revenue due to the Office, fees for services rendered, as well as other revenues. HIPO disposes over its revenues independently and uses them to cover its operation.

In order to ensure HIPO's medium-term financial stability, it would be necessary to increase the revenues from the public authority and/or the services fees.

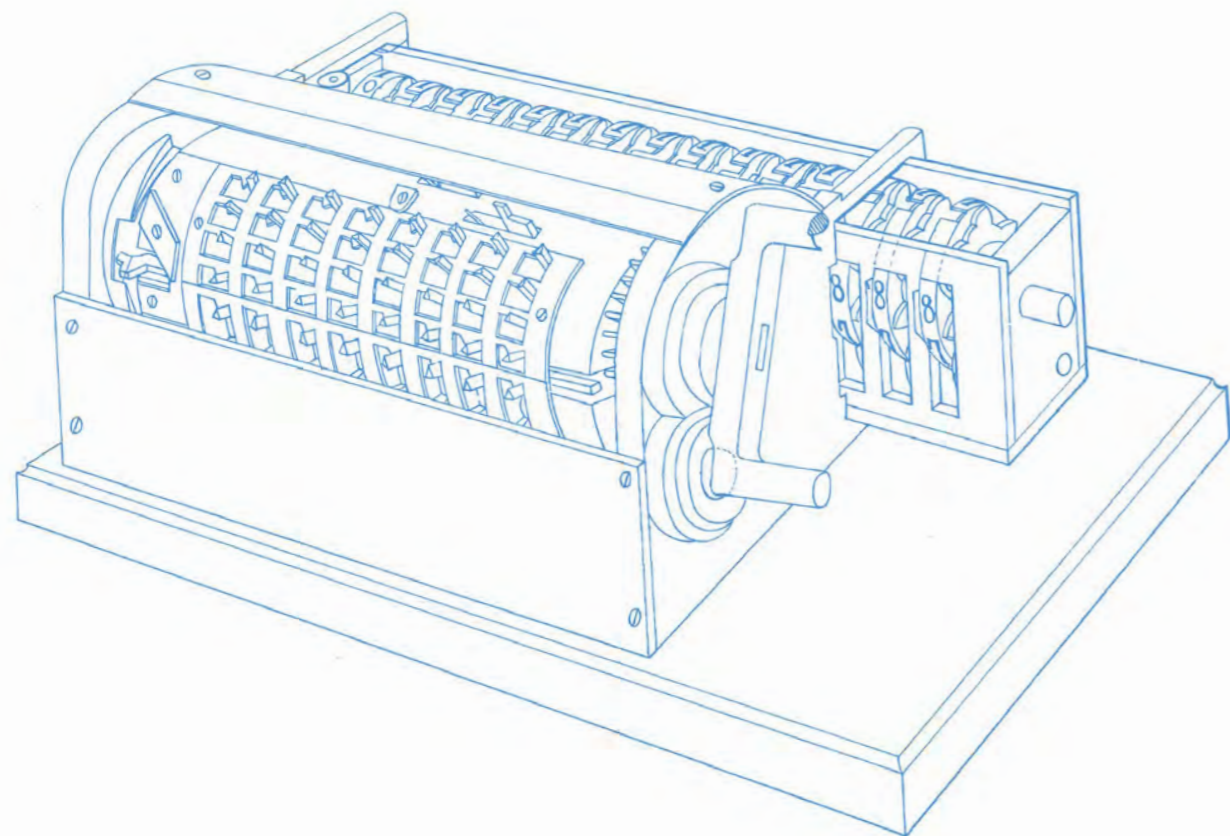

In 2023 an initial expenditure appropriation of HUF 4 240.2 M was available to ensure the continued operation of HIPO. The structure of HIPO's expenditures is stable, but with different proportions. Parallel to a decrease in personnel and operational costs, an increase was experienced in the cost of materials & services, as well as in capital expenditures. Personnel and related costs continue to account for the major part of operational costs (47.5%). Out of the remainder, 35.5% was used by the Office for current expenditures (material & services), 10.8% for other operational costs and 8.2% for capital expenditures.

At the beginning of the year the main focus was on using the HUF 323.9 million balance (the bulk of which was made up of provisions made in the previous years and shown in the accounts as residual funds). During the year 2023 the Office accumulated a surplus of HUF 518.7 M. At the end of the year, expenditure appropriations adjusted with the residual funds and the revenue surplus amounted to HUF 5 083.1, of which 91.8 % was used, resulting in actual expenditure of HUF 4 667.9 million.

47,5%
személyi juttatások
és járulékaik

33,5%
folyó (dologi)
kiadások

8,2%
beruházások
finanszírozása

10,8%
egyéb működési
kiadások

8 | Bodies

Among the bodies the HIPO plays a role in the work of the **Body of Experts on Industrial Property**, the **Council of Copyright Experts** and the **Hungarian Design Council**.

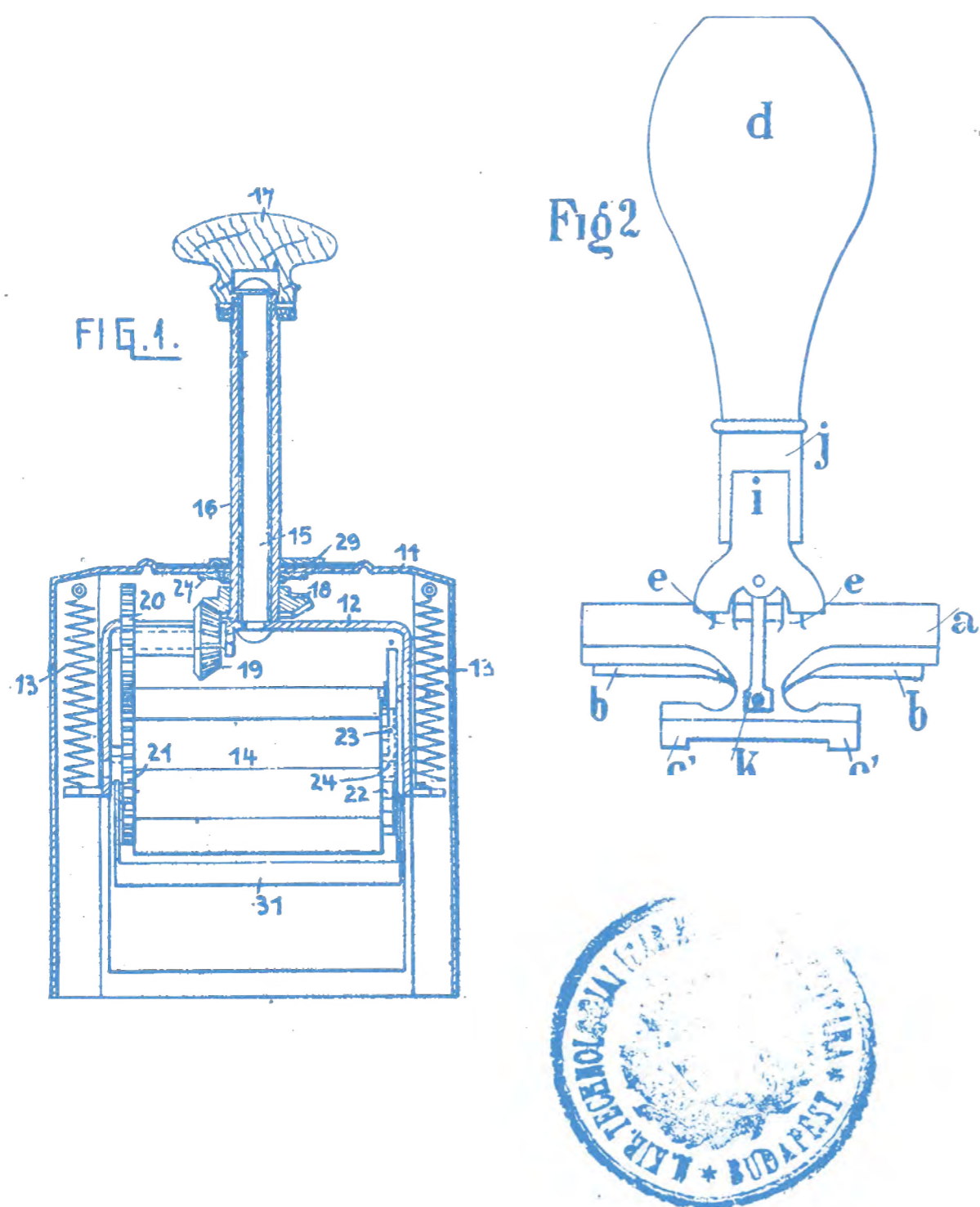

Body of Experts on Industrial Property

The Body of Experts on Industrial Property acts on the basis of requests from the courts and other authorities, as well as on behalf of customers, in specialised matters of industrial property litigation. The Body received 19 new requests and assignments in 2023, which indicates an increasing number of cases.

Council of Copyright Experts

The Council of Copyright Experts gives expert opinion to the courts and other authorities on issues arising in copyright legal disputes, and expert opinion may also be requested from the Body for out of court purposes or before the start of legal proceedings. In 2023 the Body received 25 invitations or appointments for giving expert opinion and 5 requests for supplementary expert opinion. During the year 19 expert opinions were issued.

Hungarian Design Council

As a consultative body, the Hungarian Design Council (HDC or Council) – which operated beside and financed by HIPO in 2022 and part of 2023 – draws attention to the value creation capability of the design approach. HDC is the organiser of three recognised design tenders. In the 44th edition of the **Hungarian Design Award** competition, the jury awarded 6 prizes and 6 special prizes to entries submitted in four categories. The **Design Management Awards**, established by the Council give recognition to organisations that apply design thinking and design management. Within the framework of the **László Moholy-Nagy Design Scholarship Programme**, supporting the professional development of young designers, 2 scholarship-winners were given the opportunity to do creative work.

In 2023 **Budapest Design Week** celebrated the 20th anniversary of its foundation. The internationally recognised showcase of the design profession was organised between 5 and 15 October 2023, focusing on celebrating the design community and its achievements of the past era. The festival offered 150 programmes over 10 days in Budapest and its partner cities, Pécs, Szombathely and Szeged.

According to the Government's decision, which entered into force on 1 September 2023, the responsibility of operating HDC was transferred from HIPO to the National Research, Development and Innovation Office (NRDIO). The Office of the Hungarian Design Council (HDC Office) was transferred to the National Innovation Agency (NIA), which is owned by NRDIO. According to the amended law, from this date onward, the President of the National Research, Development and Innovation Office, **Adám Kiss** will perform the tasks of the President of the Body, and the President of HIPO, **Szabolcs Farkas**, will be a member of the Body.

Imprint

Published by the Hungarian Intellectual Property Office in April 2024
Responsible publisher: Szabolcs Farkas
Editor: Krisztina Botos-Penyigey
With the contribution of: Erika Sajtiné Sándor
Peer review: Mária Mándoki, János Gács
Graphics: MITTE Communications

Translation into English: Erzsébet Andrea Horváth, Gábor Somogyi
Peer-review of the translation: ██████████

SZTNH, 2024
1081 Budapest II. János Pál pápa tér 7.
1438 Budapest, Pf. 415.
Telephone: +36 1 312 4400
www.sztnh.gov.hu

