

Procedures to file a request with the Hungarian Intellectual Property Office for Patent Prosecution Highway Pilot Program between the State Intellectual Property Office of People's Republic of CHINA (SIPO) and the Hungarian Intellectual Property Office (HIPO)

1. Request to the HIPO

An applicant shall file a request for accelerated examination under the Patent Prosecution Highway (PPH) with the HIPO by submitting a letter requesting accelerated examination under the PPH accompanied by the relevant supporting documents, including a completed PPH request form. The requirements for requesting accelerated examination under the PPH are given in paragraph 2. Relevant supporting documentation is discussed in paragraph 3 and the general HIPO application procedure envisaged in paragraph 4.

2. Requirements for requesting accelerated examination under the PPH pilot program at the HIPO

There are five requirements for requesting accelerated examination under the PPH pilot program at the HIPO. These are the following:

2.1 Requirements

(a) Using national work products from SIPO

The HIPO application (including PCT national phase application) is: (i) an application which validly claims priority under the Paris Convention to the corresponding SIPO application(s) (examples are provided in Annex 3, figure A, B, C, D, E and F), or

(ii) a PCT national phase application without priority claim (direct PCT application) (example is provided in Annex 3, figure G), or

(iii) an application which validly claims priority under the Paris Convention to the PCT application(s) without priority claim (examples are provided in Annex 3, figure H, I and J).

The HIPO application, which validly claims priority to multiple SIPO or PCT applications, or which is the divisional application validly based on the originally filed application that is included in (i) to (iii) above, is also eligible.

(b) Using PCT international work products from SIPO

The relationship between the application and the corresponding international application satisfies one of the following requirements:

(A) The application is a national phase application of the corresponding international application. (See Figures K, K' and K'' in Annex 3)

(B) The application is a national application as a basis of the priority claim of the corresponding international application.(See Figures L in Annex 3)

(C) The application is a national phase application of an international application claiming priority from the corresponding international application. (See Figure M in Annex 3)

(D) The application is a national application claiming foreign/domestic priority from the corresponding international application. (See Figure N in Annex 3)

(E) The application is the derivative application (divisional application and application claiming domestic priority etc.) of the application which satisfies one of the above requirements (A)-(D). (See Figures O1 and O2 in Annex 3)

2.2 At least one corresponding application has one or more claims that are determined to be patentable/allowable by the SIPO or the SIPO as PCT/ISA/IPEA.

Claims clearly identified to be patentable/allowable by the SIPO in the latest office action at examination stage are able to be a base of a request for accelerated examination under the PPH pilot program, even if the application, which includes those claims is not granted for patent yet.

Similarly, claims that have been determined to be patentable/allowable in the latest PCT work issued by the SIPO as PCT/ISA/IPEA are eligible to be base of a request for an accelerated examination under the PPH pilot program.

Where the SIPO application that contains the patentable/allowable claims is not the same application for which priority is claimed in the HIPO application, the applicant shall identify the relationship between the SIPO application that contains the patentable/allowable claims and the SIPO priority application claimed in the HIPO application. (Refer to Example D and E in Annex 3). Similarly, in case of doubt the applicant shall identify the relationship between the PCT application that contains the patentable/allowable claims and the HIPO application.

2.3 All claims in the HIPO application (for which an accelerated examination under the PPH pilot program is requested), as originally filed or as amended, must sufficiently correspond to one or more of those claims determined to be patentable/allowable by the SIPO.

Claims are considered to sufficiently correspond where both claims have a common technical feature which made the claims patentable/allowable over the prior art in the SIPO application. In this regard, a claim which has additional component on the claim determined to be patentable/allowable by the SIPO or the latest PCT work issued by the SIPO as PCT/ISA/IPEA or which is the same except for claim format as the claim determined to be patentable/allowable will be considered to sufficiently correspond.

A claim in the HIPO application which introduces a new/different category of claims to those indicated as patentable/allowable by the SIPO or the latest PCT work issued by the SIPO as

PCT/ISA/IPEA is not considered to sufficiently correspond. For example, where the claims in the corresponding SIPO application or in the PCT application only contain claims to a process of manufacturing a product, claims in the HIPO application will not be considered to sufficiently correspond if the HIPO application introduces product claims that are dependent upon the corresponding process claims.

Note that when claims are determined to be patentable/allowable by the SIPO or the latest PCT work issued by the SIPO as PCT/ISA/IPEA by making amendment to claims, the claims in the HIPO application shall also be amended in a similar way to sufficiently correspond to the patentable/allowable claims in the SIPO or PCT application. Claims of the HIPO application which are appended to earlier claims of the HIPO application corresponding to claims that are indicated as patentable will also be considered to sufficiently correspond where such claims fall within the scope of the claims indicated as patentable. (See Annex 1)

2.4 A “Request for Examination” shall be filed with the HIPO and the national fee of the substantive examination shall also be paid either at the time or before the filing of the PPH request.

2.5 The HIPO has not issued a “Letter relating to Intention to Grant” (The heading of the communication is “Felhívás nyilatkozattételre és megadási díj megfizetésére”, letter code “SM”) yet.

3. Documents to be submitted

The applicant is required to complete a form for requesting accelerated examination under the PPH pilot program (as given in Annex 2) which is available for download from the HIPO’s website (<http://www.sztnh.gov.hu/English/szabadalom/pph/>). The form shall be sent to the HIPO along with the relevant supporting documentation as detailed in paragraphs 3.1 to 3.4.

Where the applicant has already submitted documents according to paragraphs 3.1 to 3.4 to the HIPO through simultaneous or past procedures, he may incorporate them by reference and does not have to attach them.

The following documentation will be needed to support a request for accelerated examination under the PPH pilot program at the HIPO:

3.1 Copies and translation of all office actions in the SIPO or the latest PCT work product of SIPO as PCT/ISA/IPEA

(a) “Office actions” are documents which relate to examination and which were sent to the applicant by the SIPO examiner.

Office actions of SIPO mentioned above are:

- a) *Decision to Grant a Patent*
- b) *First/Second/Third/...Office action*
- c) *Decision of Refusal*
- d) *Reexamination Decision, and*
- e) *Invalidation Decision*

Both Hungarian and English are acceptable as translation language. Machine translations are admissible, but if it is impossible for the examiner to understand the outline of the translated office action due to insufficient translation, the examiner may request the applicant to provide additional translation.

The applicant does not have to submit the copy and translation of the office actions when those documents are provided via "The China Patent Inquiry System" (http://www.cpquery.gov.cn/index.jsp?language=en_us) of the SIPO. However, if the HIPO examiner is not able to obtain them via the "The China Patent Inquiry System" or understand the translated claims, the HIPO examiner may request the applicant to provide additional translation. If the SIPO Office action does not explicitly state that a particular claim is allowable, the applicant must include a statement along the request for accelerated examination under the PPH that no rejection has been made in the SIPO Office action regarding that claim, and therefore, the claim is deemed to be allowable by the SIPO. For example, if claims are not shown in the item of "6. the Opinion on the Conclusion of Examination about Claims" in the "First Notice of the Opinion on Examination" or "5. the Opinion on the Conclusion of Examination about Claims" in the "Second/Third/... Notice of the Opinion on Examination" issued by the SIPO, those claims may be deemed to be implicitly identified to be allowable/patentable and then the applicant must include the above explanation.

(b) Any of the latest work product issued by the SIPO as PCT/ISA/IPEA in the international phase of a PCT application corresponding to the application ("PCT work product"), namely the "Written Opinion of International Searching Authority (WO/ISA)", the "Written Opinion of International Preliminary Examining Authority (WO/IPEA)" or the "International Preliminary Examination Report (IPER)", is also eligible if it indicates at least one claim as patentable/allowable (from the aspect of novelty, inventive steps and industrial applicability). The applicant cannot file a request under the PPH on the basis of an International Search Report (ISR) only.

In case the application satisfies the relationship 2.1(b)(A), the applicant does not need to submit a copy of the International Preliminary Report on Patentability (IPRP) because a copy of these documents is already available in the file-wrapper of the application. In addition, if the copy of the latest international work product is available via PATENTSCOPE^{®1*}, an applicant does not need to submit these documents, unless otherwise requested by the HIPO (WO/ISA and IPER are

¹ <http://www.wipo.int/pctdb/en/index.jsp>

usually available as "IPRP Chapter I" and "IPRP Chapter II" respectively after 30 months from the priority date.).

In case any observation is described in Box VIII of WO/ISA, WO/IPEA or IPER which forms the basis of a PPH request to the HIPO, the applicant shall explain why the claim(s) is/are not subject to the observation irrespective of whether or not an amendment is submitted to correct the observation.

Both Hungarian and English are acceptable as translation language. Machine translations are admissible however, if the (machine) translation is insufficient, the HIPO examiner may request the applicant to provide additional translation.

3.2 Copies and translations of all claims determined to be patentable/allowable by the SIPO or SIPO as PCT/ISA/IPEA

The copy of the claims determined to be patentable/allowable by the SIPO or SIPO as PCT/ISA/IPEA might be either:

- a copy of the document submitted at initial filing which includes claims determined to be patentable/allowable where no later amendments to the claims have been made, or
- a copy of the amendments which includes claims determined to be patentable/allowable where later amendments to the claims have been made, or
- a copy of the SIPO's publication of the granted patent, or
- a copy of the PCT international application which includes claims determined to be patentable/allowable where no later amendments to the claims have been made, or
- a copy of the amendments in the PCT phase which includes claims determined to be patentable/allowable where later amendments to the claims have been made.

Both Hungarian and English are acceptable as translation language.

Provisions in paragraph 3.1 regarding the occasions where the applicant is not required to submit copies and translations and regarding machine translations also apply to paragraph 3.2.

3.3 Copies of references cited by the SIPO examiner or in the latest PCT work issued by the SIPO as PCT/ISA/IPEA

If the cited references are patent documents, the applicant does not have to submit them because the HIPO usually possesses them. In case the HIPO patent examiner has difficulty in obtaining the document, however, the applicant may be asked to submit it.

Non-patent literature shall always be submitted.

Submission of translation of the references is not required. However, applicants are encouraged to file translations as part of the supporting documentation when initially requesting accelerated examination under the PPH to allow prompt consideration of the citations if they so desire.

3.4 Claim correspondence table

The applicant shall submit a claim correspondence table to explain the correspondence of claims determined to be patentable/allowable by the SIPO or the SIPO as PCT/ISA/IPEA and all claims in the HIPO application. The claims correspondence table must indicate how all the claims in the HIPO application correspond to the allowable/patentable claims in the SIPO or PCT application. When claims are just literal translation, the applicant can just write down that “they are same” in the table. When claims are not just literal translation, it is necessary to explain the sufficient correspondence of each claim based on the criteria in paragraph 2.3. (See also Annex 1 for the examples of the claim correspondence).

Claims are considered to satisfy the sufficient correspondence where, accounting for differences due to translations and claim format requirements, the claims in the HIPO application are of the same or similar scope as the claims indicated as having novelty, inventive step and industrial applicability and - in case of a PCT application - are free of any observation described in Box VIII in the latest PCT work product of the corresponding PCT application, or the claims in the HIPO application are narrower in scope than the claims indicated as having novelty, inventive step and industrial applicability and free of any observation described in Box VIII in the latest PCT work product of the corresponding PCT application. In this regard, a claim that is narrower in scope occurs when a claim is amended to be further limited by an additional feature that is supported in the specification (description and/or claims).

4. Procedure for accelerated examination under the PPH pilot program at the HIPO

The applicant files a request form for the accelerated examination under the PPH pilot program to the HIPO along with the documents referred to in paragraph 3. The applicant is not required to pay a fee for accelerated examination under the PPH.

The HIPO decides whether the application can be entitled to the status for an accelerated examination under the PPH when it receives a request with the documents stated in paragraph 3. When the HIPO decides that the request is acceptable, the application is assigned a special status for an accelerated examination under the PPH and the applicant is notified accordingly.

Where the request does not meet all the requirements set forth in this document, the applicant will be notified and the defects in the request will be identified. The applicant will be given the opportunity to correct the request. If not corrected, the applicant will be notified and the application will await action in its regular turn.

Examples for the claim correspondence

The claims in the following cases are considered to “sufficiently correspond”.

EX.1

<i>OFF² claims</i>	<i>OSF³ claims</i>	<i>Comment</i>
1	1	<i>The OSF claim has the additional component on the OFF granted claim.</i>

OFF granted claim	OSF claim
<p>A system for presenting a container storing at least one article to a processing tool, comprising:</p> <p>(a) a load port, including:</p> <p style="padding-left: 20px;">a frame having an opening;</p> <p style="padding-left: 20px;">a support structure being adapted to receive a container, and</p> <p style="padding-left: 20px;">a drive mechanism for moving said support structure substantially vertically between a first height and a second height; and</p> <p>(b) a conveyor for movably supporting the container substantially along a container transport plane;</p> <p style="padding-left: 20px;">wherein a container traveling on said conveyor moves unobstructed over said support structure when said support structure is located in said second height,</p> <p style="padding-left: 20px;">wherein the container traveling unobstructed does not contact said support structure while traveling over said support structure located at said second height,</p> <p style="padding-left: 20px;">wherein said support structure, when located at said second height, is located below said transport plane.</p> <p><u>*This additional part is NOT included in the OFF granted claim but it is included in the description of the OFF application</u></p>	<p>A system for presenting a container storing at least one article to a processing tool, comprising:</p> <p>(a) a load port, including:</p> <p style="padding-left: 20px;">a frame having an opening;</p> <p style="padding-left: 20px;">a support structure being adapted to receive a container, and</p> <p style="padding-left: 20px;">a drive mechanism for moving said support structure substantially vertically between a first height and a second height; and</p> <p>(b) a conveyor for movably supporting the container substantially along a container transport plane;</p> <p style="padding-left: 20px;">wherein a container traveling on said conveyor moves unobstructed over said support structure when said support structure is located in said second height,</p> <p style="padding-left: 20px;">wherein the container traveling unobstructed does not contact said support structure while traveling over said support structure located at said second height,</p> <p style="padding-left: 20px;">wherein said support structure, when located at said second height, is located below said transport plane,</p> <p style="padding-left: 20px;"><u>wherein said support structure, when located at said first height, is located above said transport plane*</u></p>

² Office of First Filing

³ Office of Second Filing

EX.2

<i>OFF claims</i>	<i>OSF claims</i>	<i>Comment</i>
1	1	Same
none	2	The OSF claim2 is dependent on the OSF claim1, which has been granted at OFF.

OFF granted claim	OSF claim
1. A nitride-based semiconductor device comprising: a first semiconductor layer, consisting of either an n-type nitride-based semiconductor layer having a wurtzite structure or an n-type nitride-based semiconductor substrate having a wurtzite structure; and an n-side electrode formed on a back surface of said first semiconductor layer, wherein a dislocation density is not more than $1 \cdot 10^9 \text{ cm}^2$ in the vicinity of the interface between said first semiconductor layer and said n-side electrode, and contact resistance between said n-side electrode and said first semiconductor layer is not more than $0.05 \text{ } \Omega \text{ cm}^2$	1. (Same)
2. (None)	2. The nitride-based semiconductor device according to claim 1, wherein said first semiconductor layer includes an n-type dopant.*

*This additional part is NOT included in the OFF granted claim but it is included in the description of the OFF application

PPH REQUEST

Request for Accelerated Examination at the HIPO under the Patent Prosecution Highway Pilot Program between the HIPO and the SIPO

1. HIPO application number: _____

Corresponding SIPO application number(s): _____

or

Corresponding PCT application number(s): _____

2. **Either:**

a) Copy of SIPO office action(s) attached:

or

b) SIPO office action(s) available via DAS of the SIPO

or

c) office action available via the WIPO public electronic database
(**PATENTSCOPE[®]**)

or

d.) SIPO office action(s) on file from previous PPH application:

HIPO application number: _____

3. Either:

a) Copy of claims of corresponding SIPO application attached:

or

b) Claims of corresponding SIPO application available via DAS of the SIPO:

or

c) Copy of claims of corresponding PCT application available via the WIPO public electronic database (**PATENTSCOPE®**)

or

d.) SIPO application claims on file from previous PPH application:

HIPO application number: _____

4. Copy of translated

a) SIPO office action(s) attached:

or

b) SIPO office action(s) available via DAS of the SIPO

or

c) office action available via the WIPO public electronic database (**PATENTSCOPE®**)

or

d) SIPO office action(s) on file from previous PPH application:

HIPO application number: _____

5. Copy of translated claims of

a) corresponding SIPO application attached:

or

b) corresponding SIPO application available
via DAS of the SIPO:

or

c) corresponding PCT application
available in WIPO public electronic database (**PATENTSCOPE[®]**)

or

d) SIPO application on file from previous PPH application:

HIPO application number: _____

6. Translated version of foreign language citation attached

(Please note that it is not necessary to provide translation of documents. However, applicant will be free to file translations to allow prompt consideration of the citations if they so desire.)

7. Claim correspondence table completed

8. Further requirements

Request for substantive examination filed and the national fee paid previously

or

Request for substantive examination is made along with the PPH request*

*Please note that the request for substantive examination is fee based and the national fee must have been paid at latest by the date of the PPH request.

PLEASE MAKE SURE THAT THIS FORM IS THE UPPERMOST DOCUMENT WHEN REQUESTING PPH

Examples of HIPO application eligible for the PPH

Figure A: A case meeting requirement (a)
- Paris Route

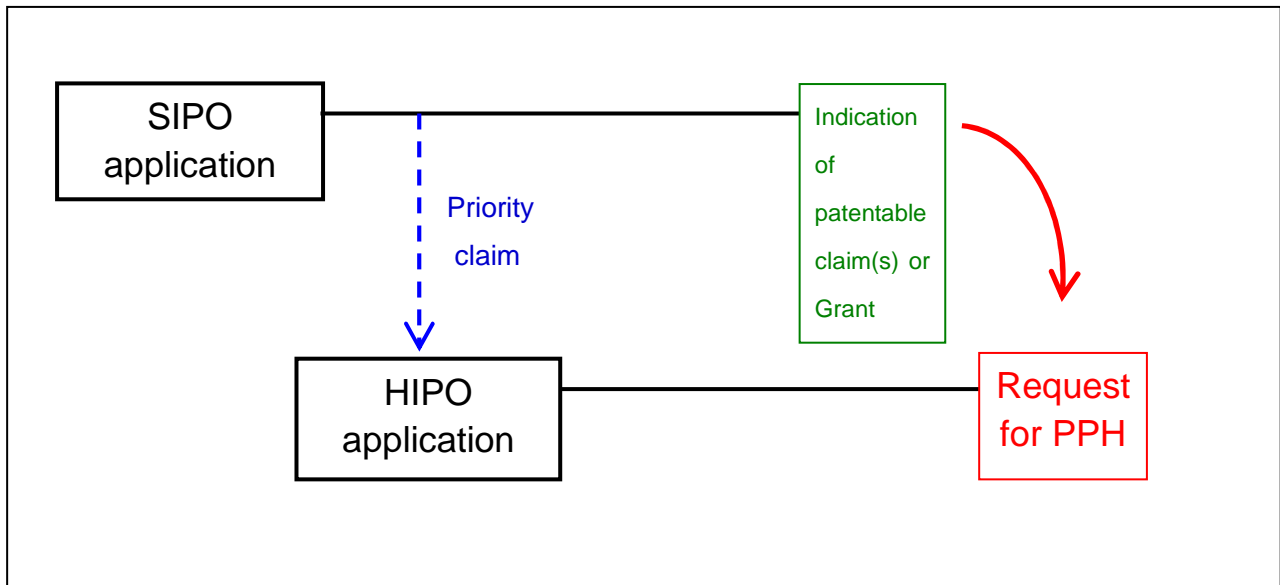
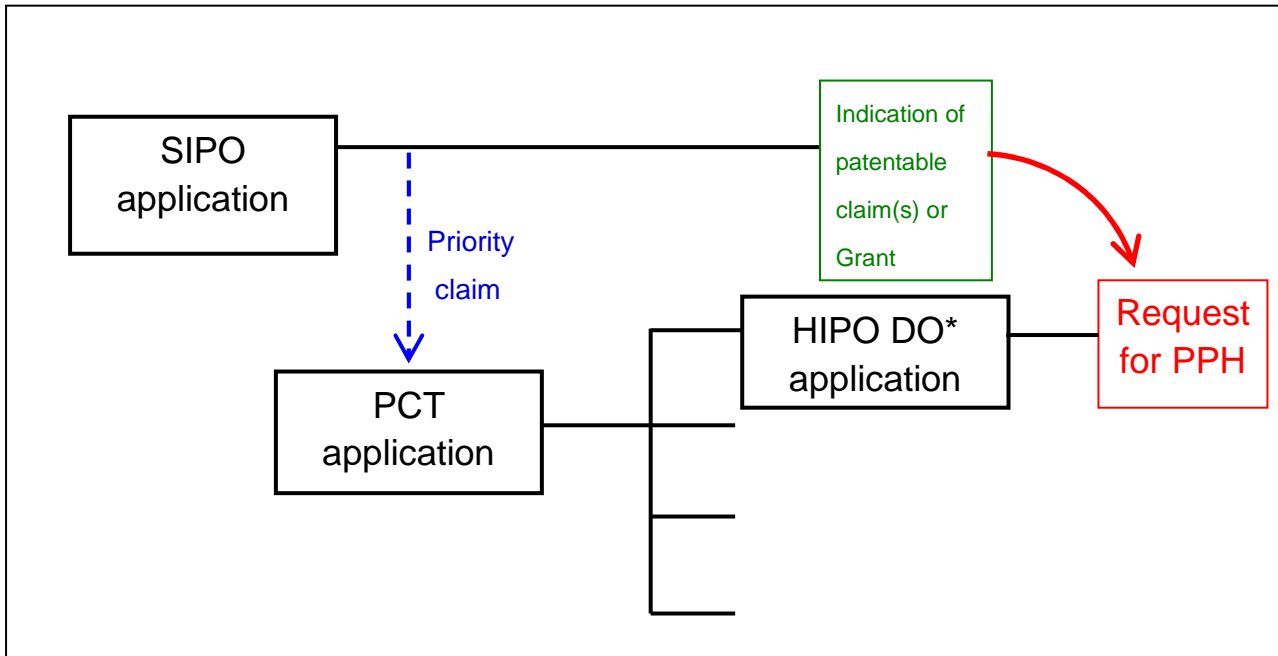

Figure B: A case meeting requirement (a)
- Paris Route and PCT Route



*DO – Designated Office

Figure C: A case meeting requirement (a)
 - Paris Route and Complex Priority (ZZ: any other priority application)

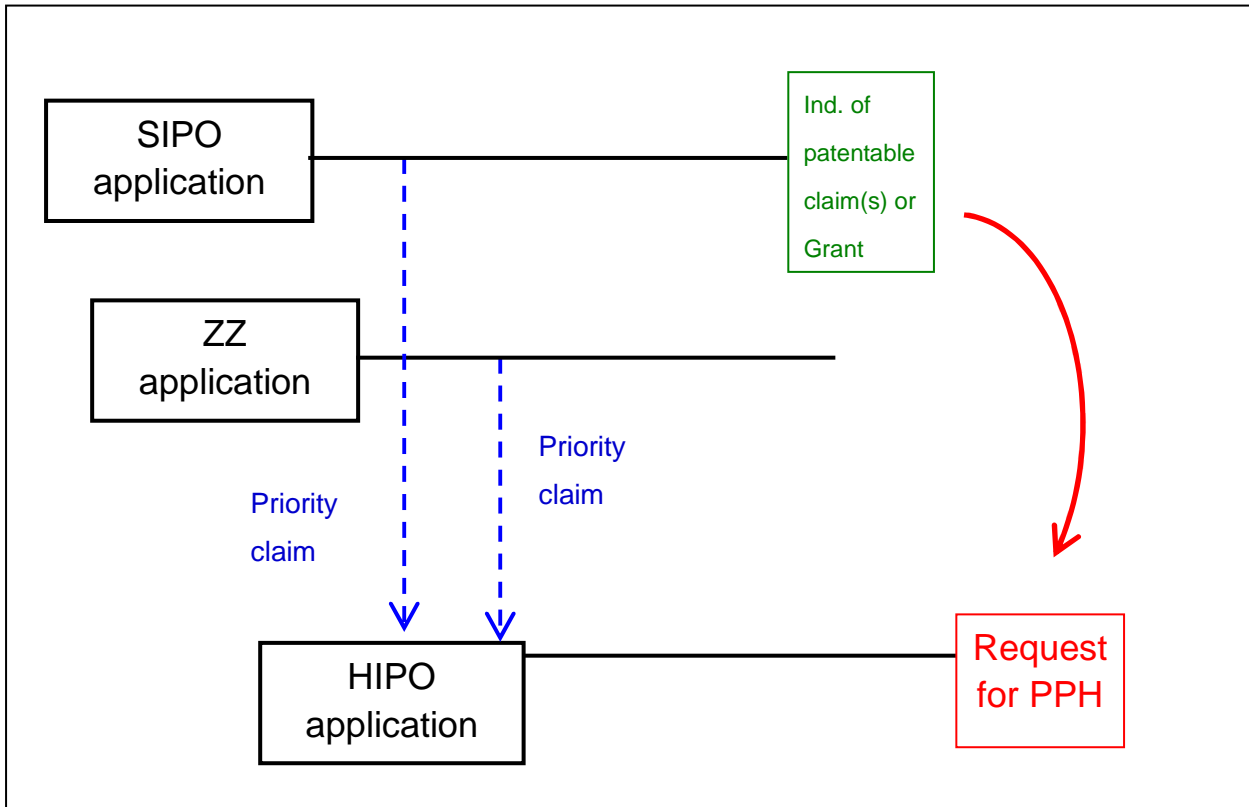

Figure D: A case meeting requirement (a)
 - Paris Route and Domestic Priority

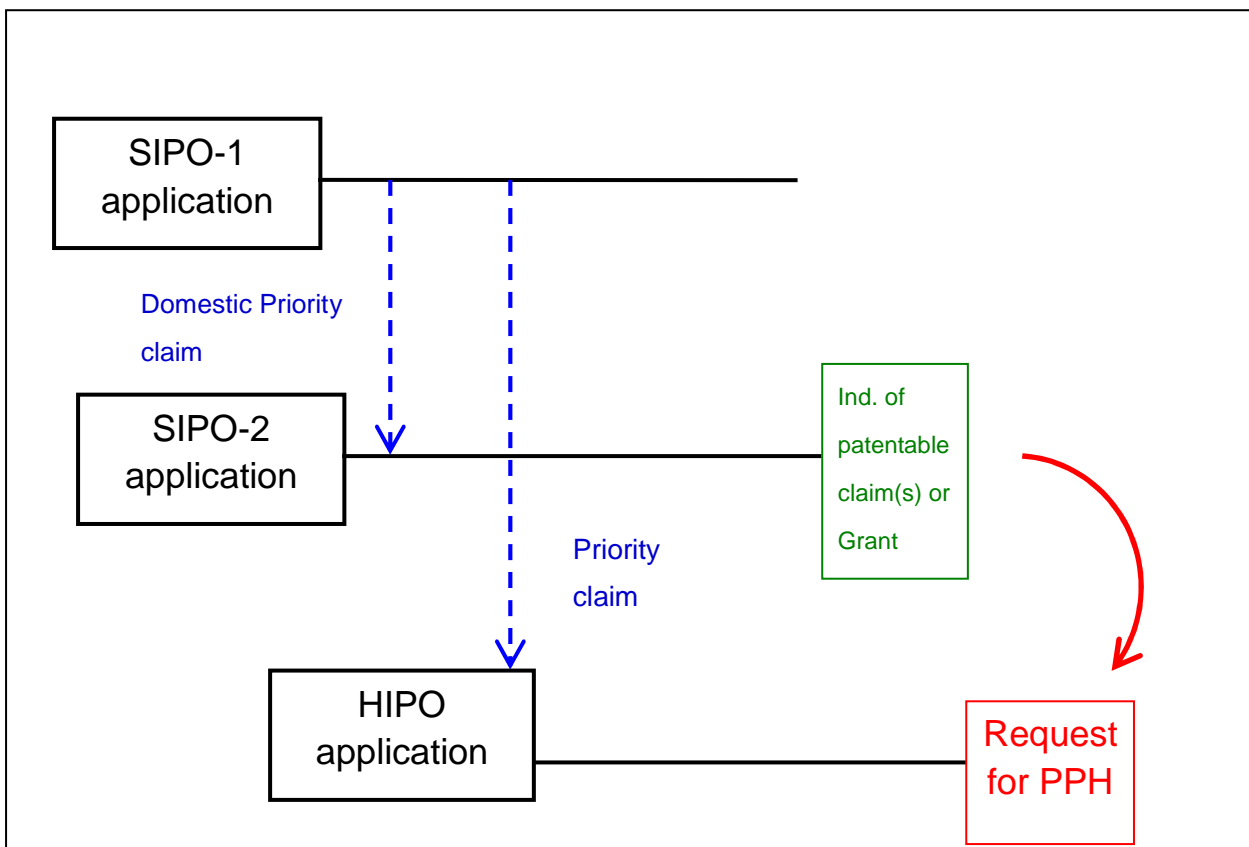

Figure E: A case meeting requirement (a)
- Paris Route and Divisional Application

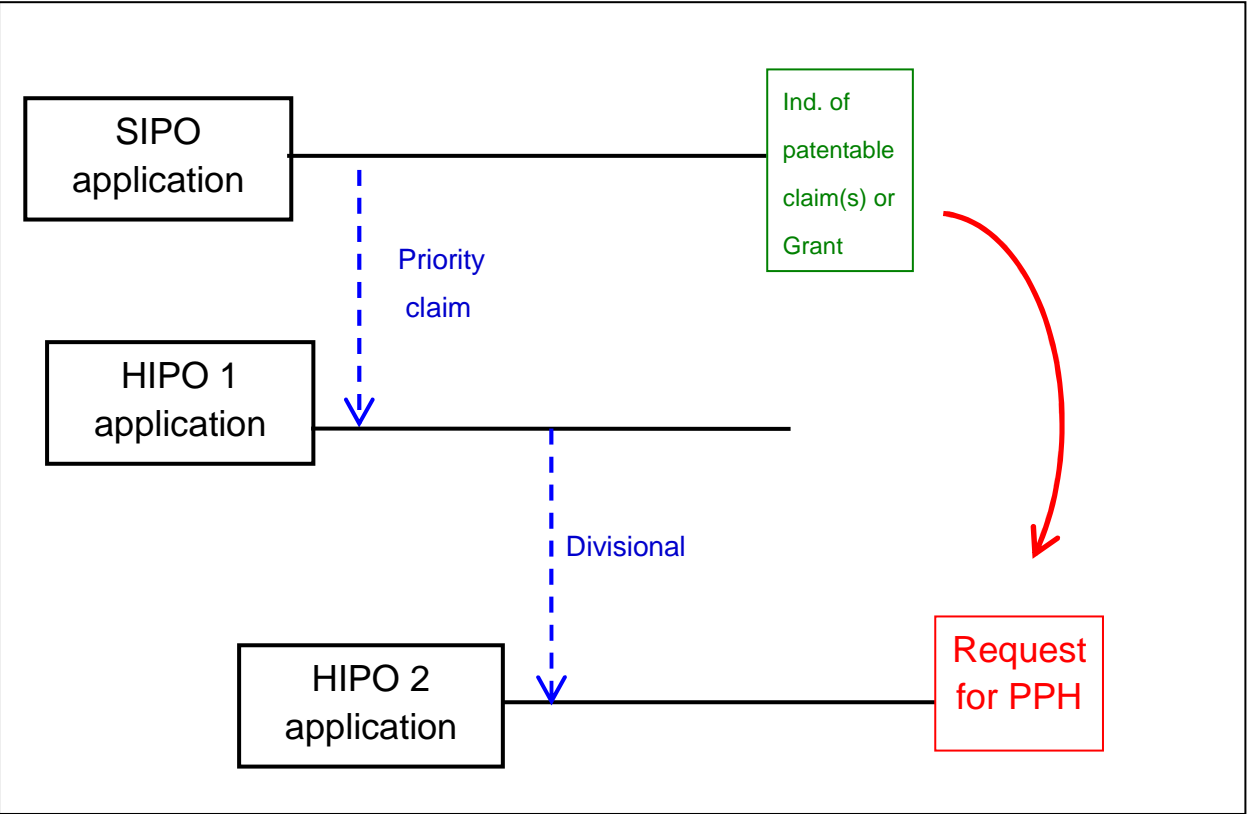

Figure F: A case meeting requirement (a)
- Paris Route and PCT Route

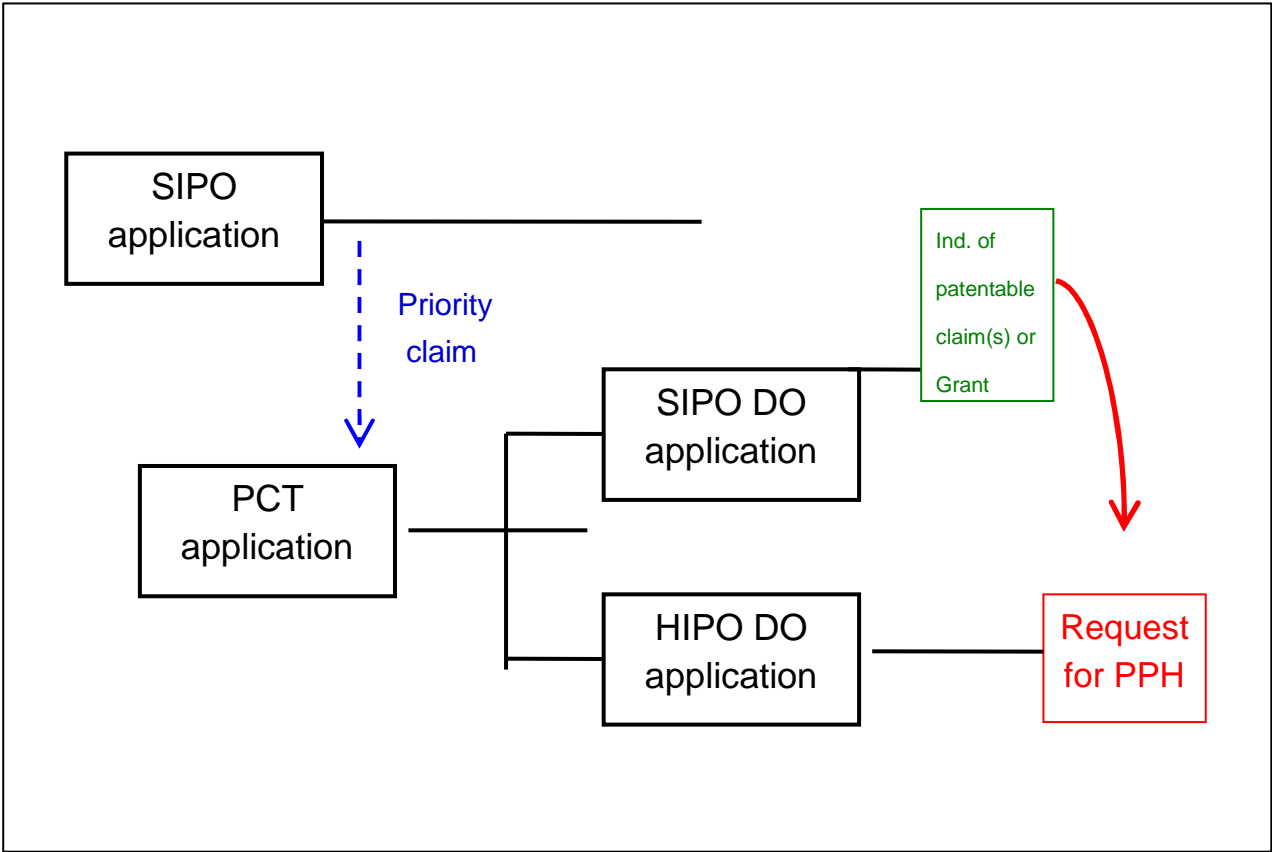

Figure G: A case meeting requirement (a)
- Direct PCT Route

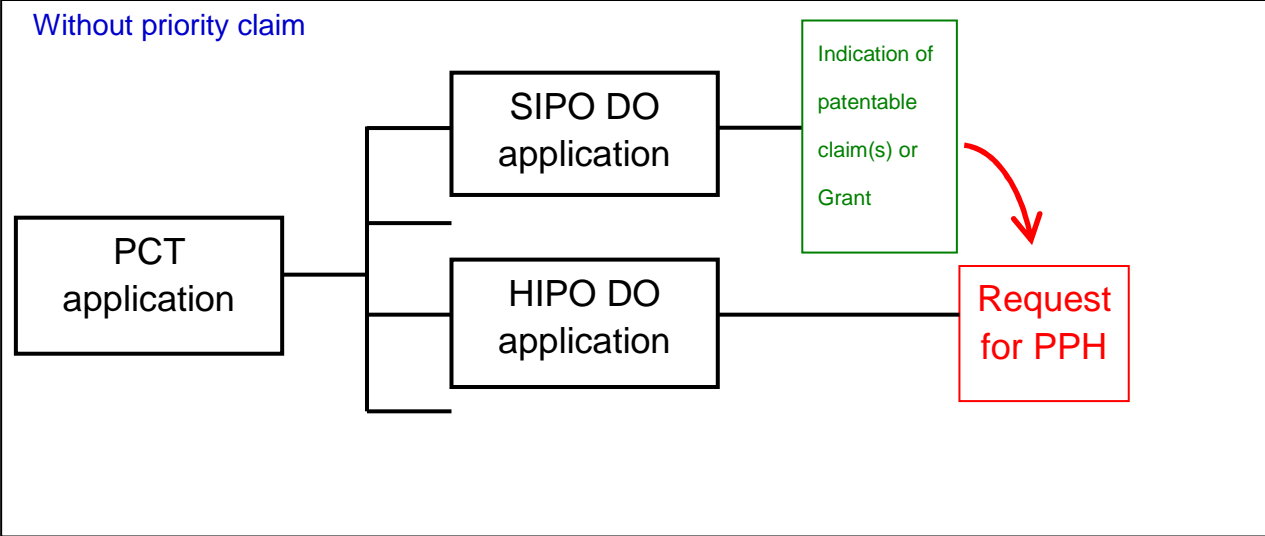

Figure H: A case meeting requirement (a)
- Direct PCT Route and Paris Route

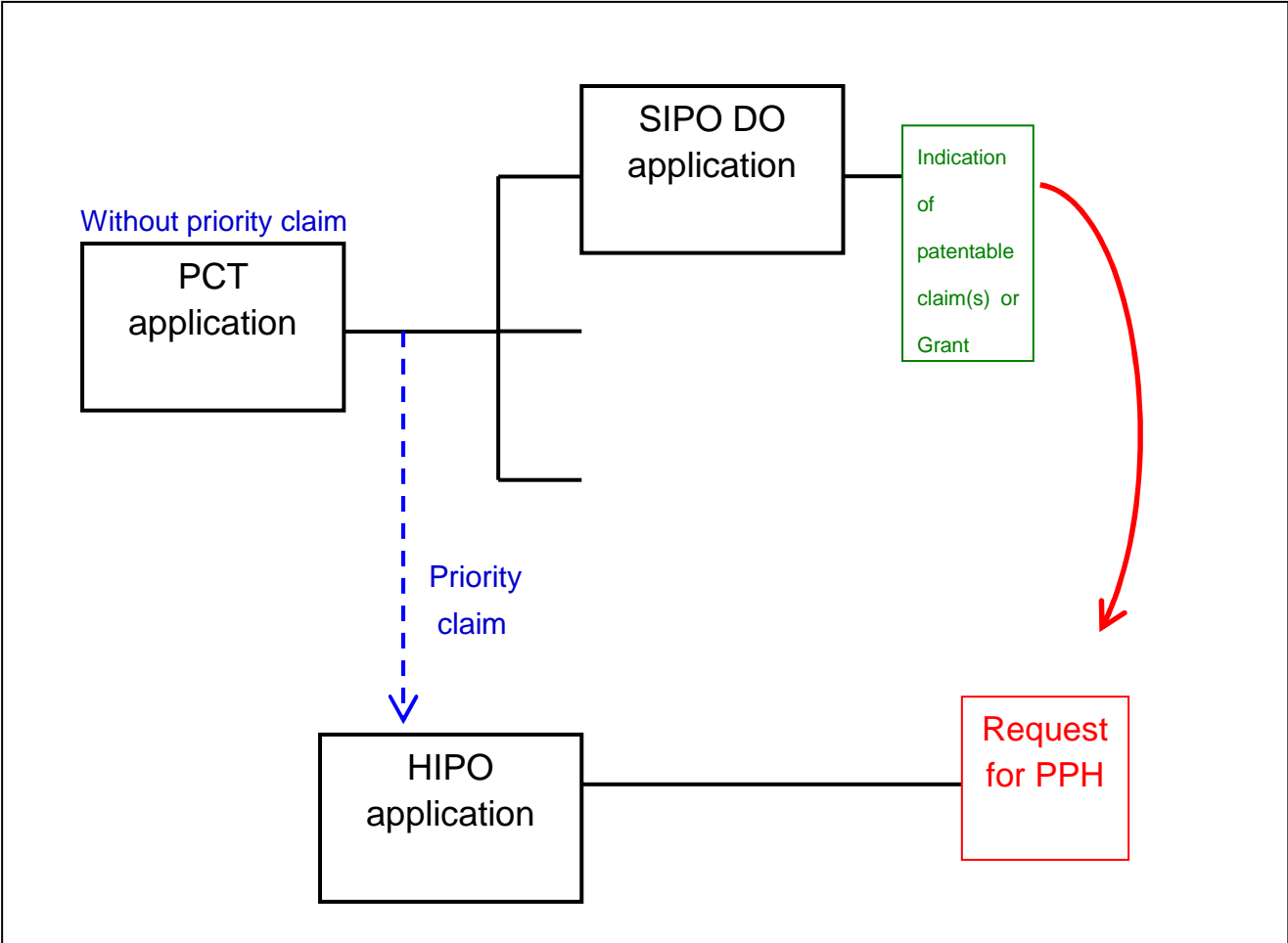

Figure I: A case meeting requirement (a)
 - Direct PCT Route and Paris Route

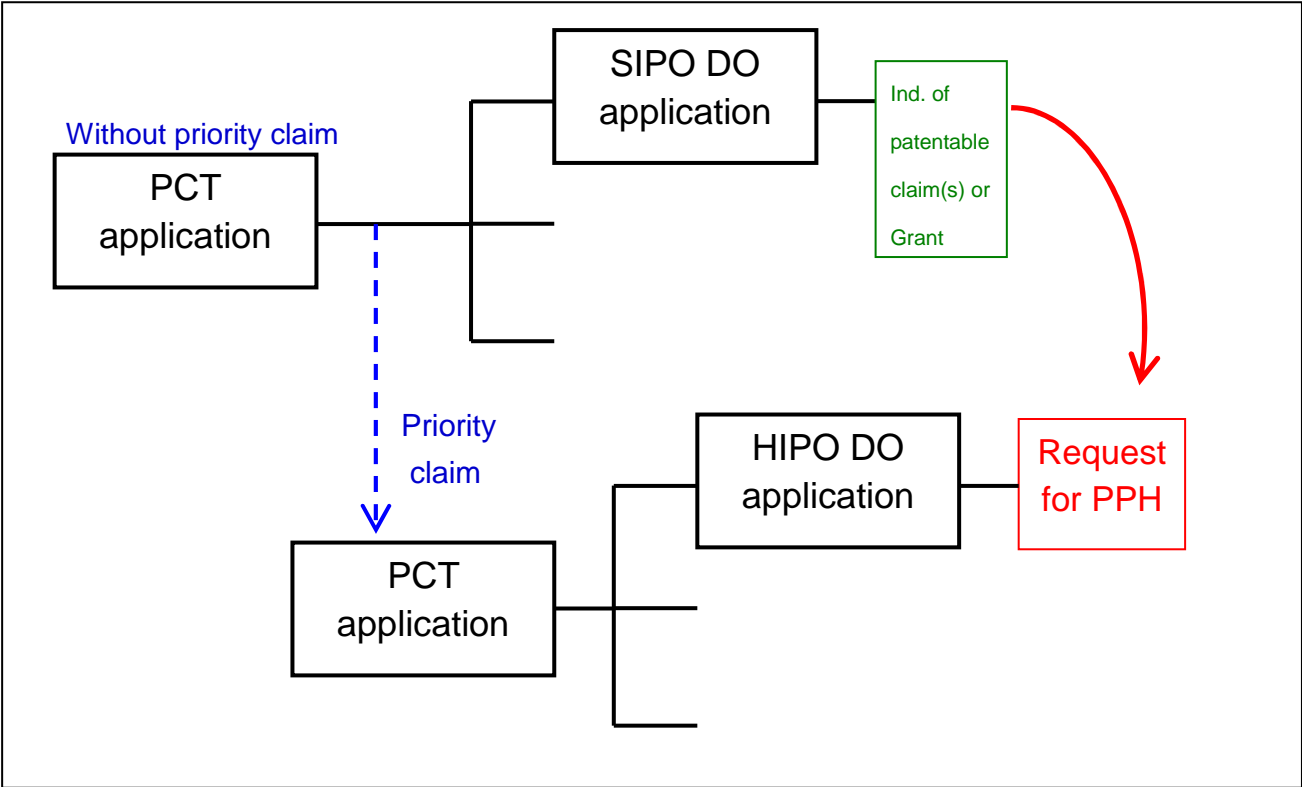

Figure J: A case meeting requirement (a)
 - Paris Route and PCT Route

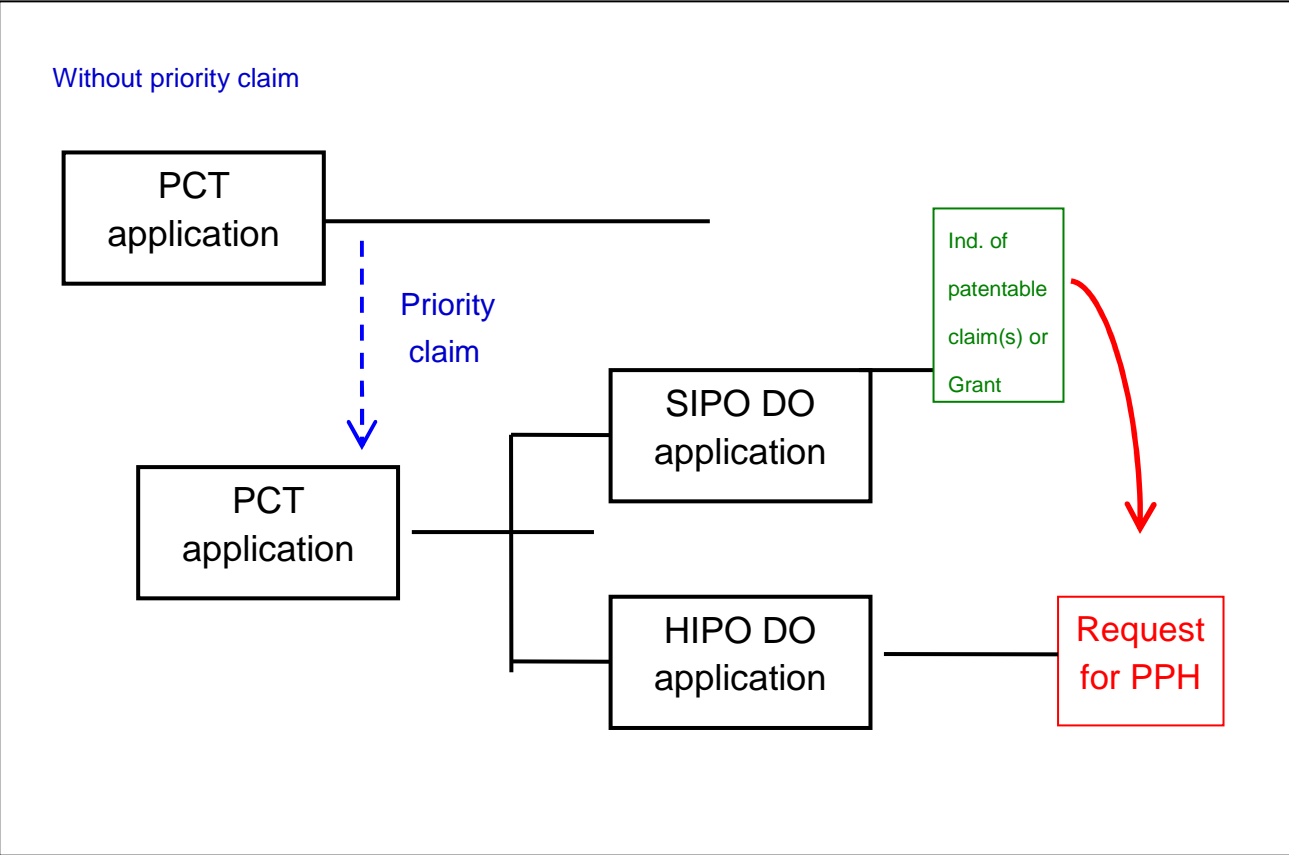

Figure K: A case meeting requirement (b)

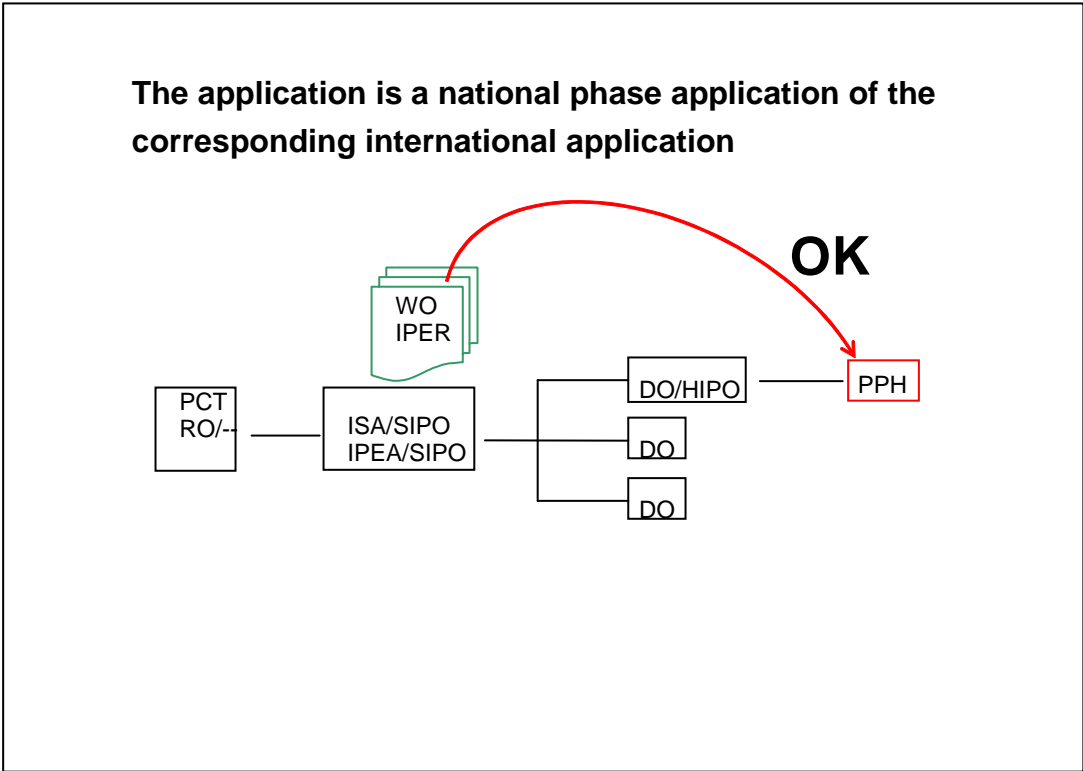

Figure K': A case meeting requirement (b)

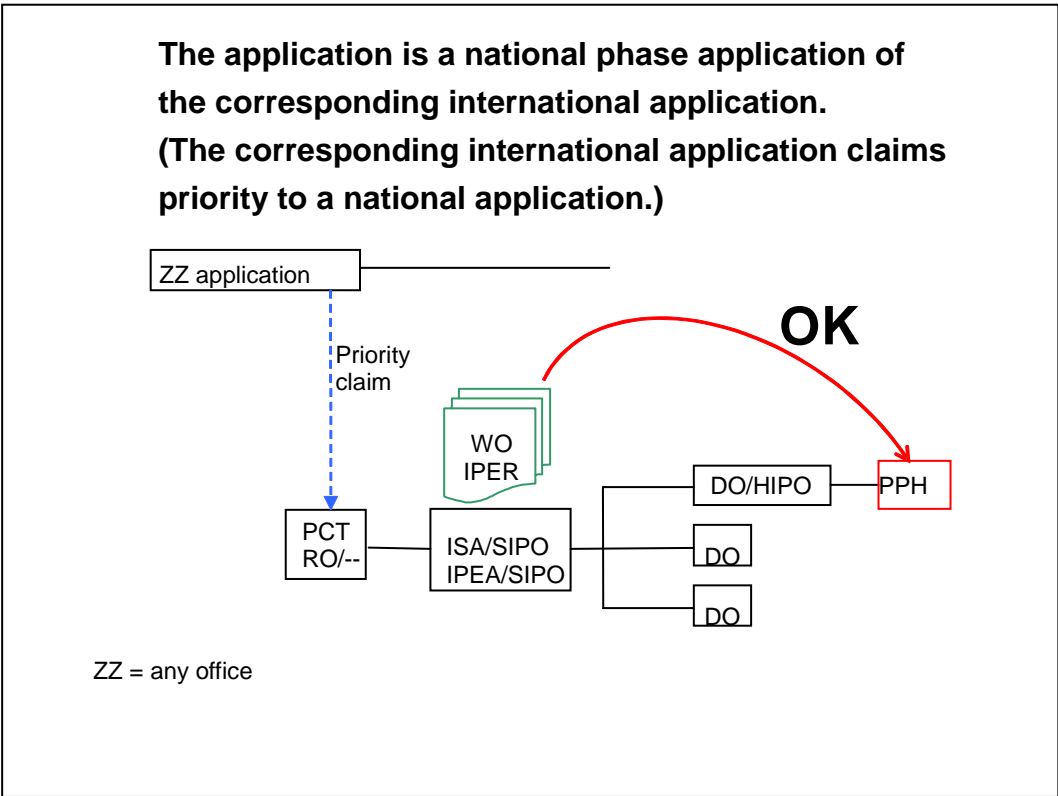

Figure K'': A case meeting requirement (b)

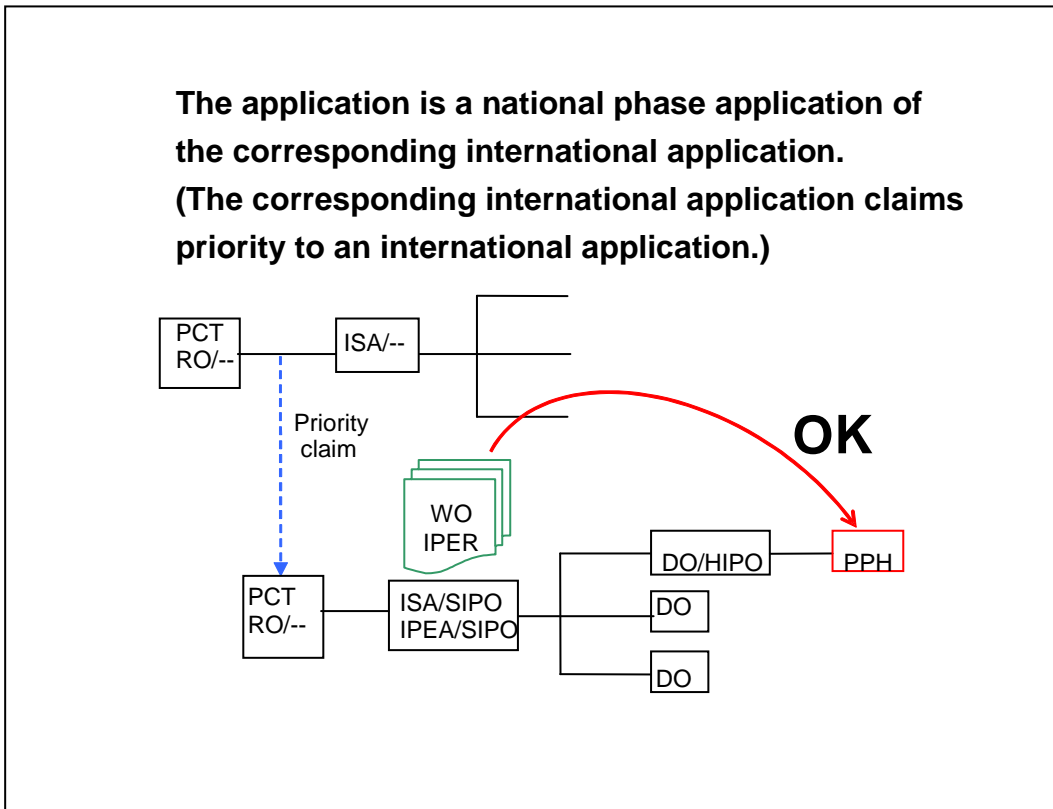

Figure L: A case meeting requirement (b)

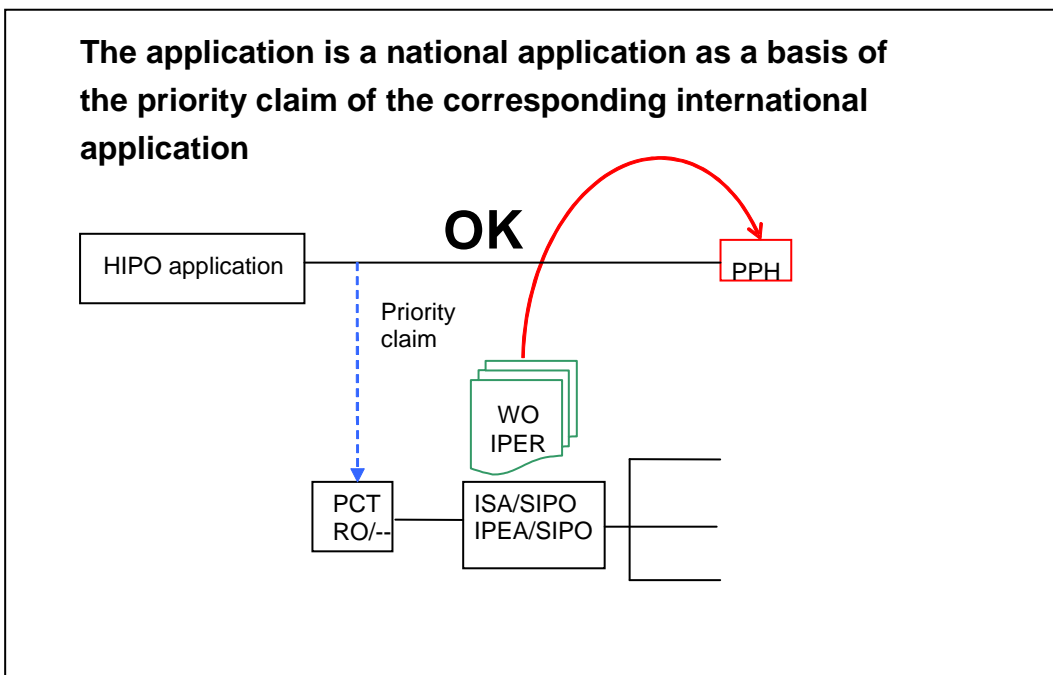

Figure M: A case meeting requirement (b)

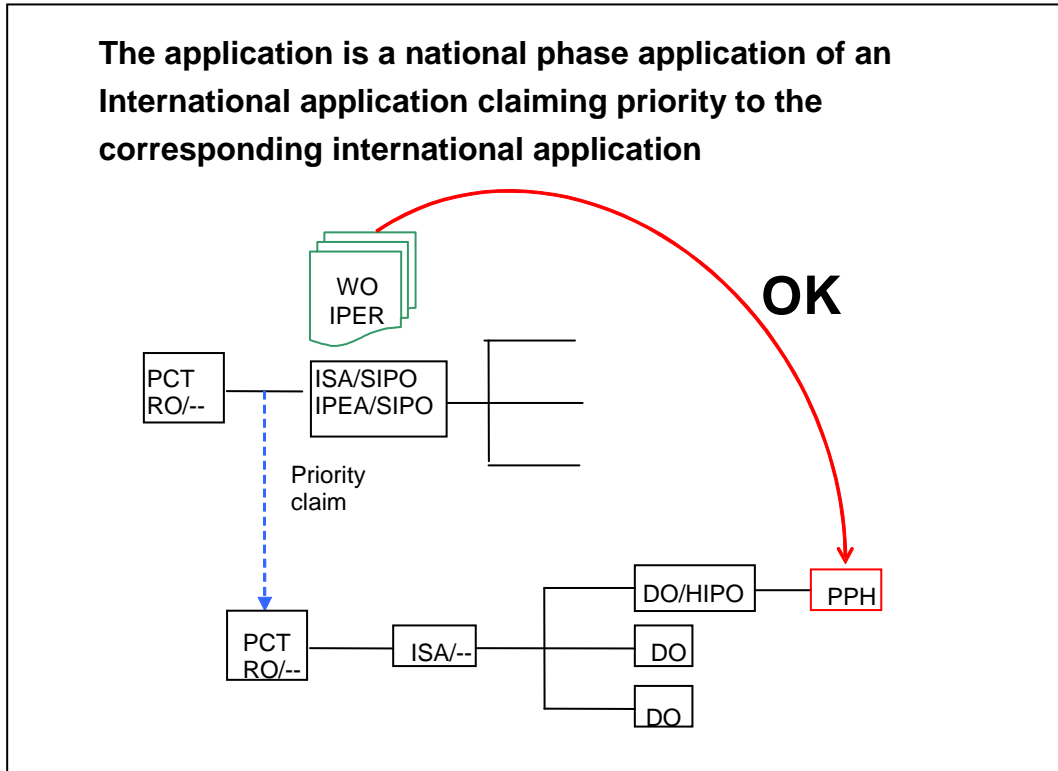

Figure N: A case meeting requirement (b)

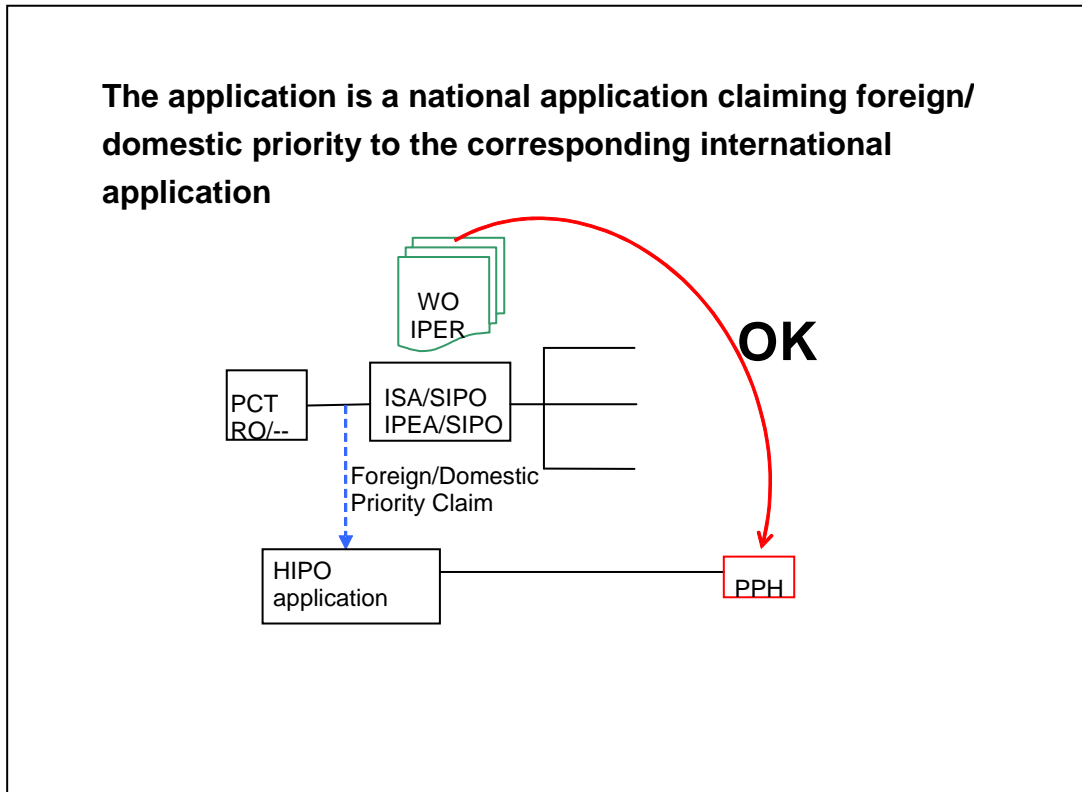

Figure O1: A case meeting requirement (b)

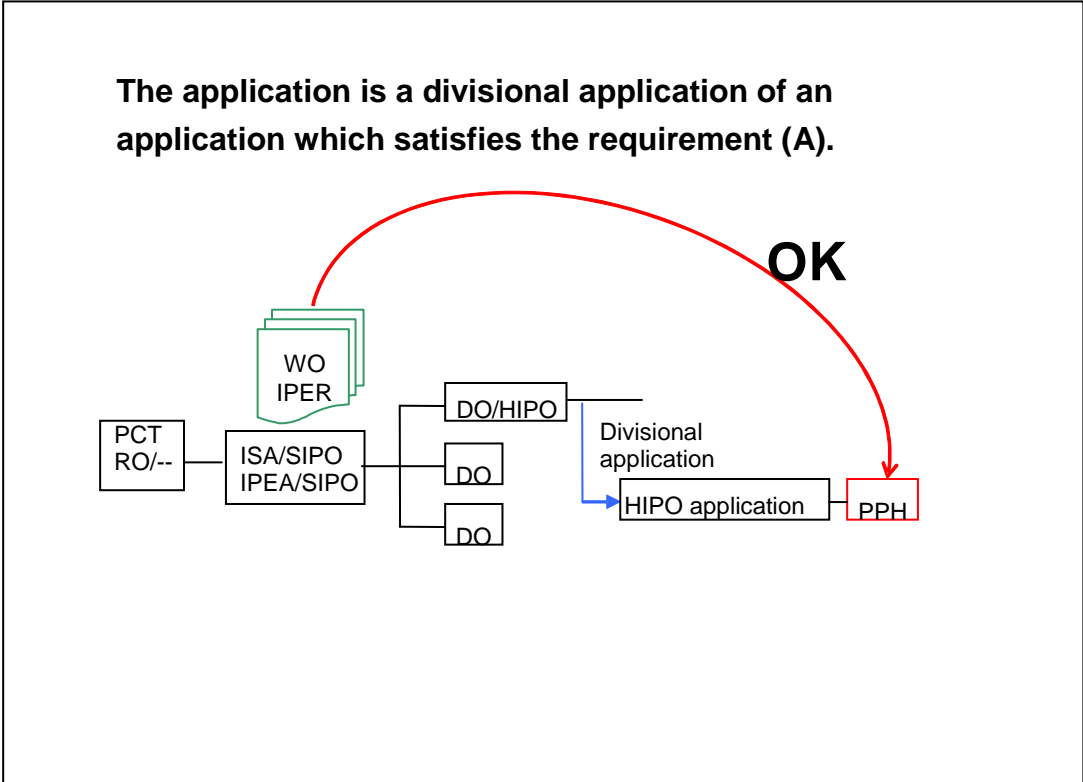

Figure O2: A case meeting requirement (b)

